

 **MITSUBISHI**
HEAVY INDUSTRIES
AIR CONDITIONERS

HEAVY DUTY

MOVE THE WORLD FORWARD  **MITSUBISHI**
HEAVY
INDUSTRIES
GROUP

SR series

Residential Air-Conditioners

2019



INDEX

PRODUCT LINE-UP 03

HIGH EFFICIENCY 04

















































AIR FLOW 06

CLEAN AIR 11

FUNCTIONS 13

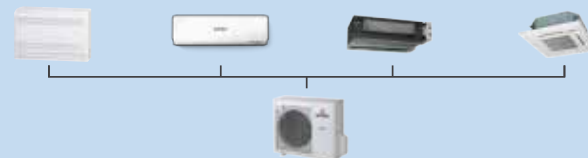

PRODUCT LINE-UP

CATEGORY	TYPE	SERIES	PAGE	CAPACITY RANGE								
				5,000BTU	7,000BTU	9,000BTU	12,000BTU	15,000BTU	18,000BTU	21,000BTU	24,000BTU	28,000BTU
				1.5 KW	2.0 KW	2.5KW	3.5KW	4.5KW	5.0KW	6.0KW	7.0KW	8.0KW
INVERTER SINGLE SPLIT	DIAMOND (COOLING & HEATING)	ZSX	15		 SRK20ZSX-S	 SRK25ZSX-S	 SRK35ZSX-S		 SRK50ZSX-S	 SRK60ZSX-S		
	PREMIUM (COOLING & HEATING)	ZS	16		 SRK20ZS-S	 SRK25ZS-S	 SRK35ZS-S		 SRK50ZS-S			
		ZR	16							 SRK63ZR-S	 SRK71ZR-S	 SRK80ZR-S
	STANDARD (COOLING & HEATING)	ZSP	17			 SRK25ZSP-S	 SRK35ZSP-S	 SRK45ZSP-S				
	DELUXE (COOLING)	YVS	18			 SRK10YVS-W	 SRK13YVS-W		 SRK18YVS-W		 SRK24YVS-W	
	STANDARD (COOLING)	YW	19			 SRK10YW-W	 SRK13YW-W	 SRK15YW-W	 SRK18YW-W		 SRK24YW-W	
	PREMIUM (COOLING)	YL/YLV	20			 SRK10YL-S/YLV-S	 SRK13YL-S/YLV-S		 SRK18YL-S/YLV-S			
STANDARD (COOLING)	YN	21			 SRK10YN-S	 SRK13YN-S		 SRK18YN-S				
CONSTANT SPEED SINGLE SPLIT	DELUXE (COOLING)	CVS	22			 SRK10CVS-W	 SRK13CVS-W		 SRK19CVS-W		 SRK25CVS-W	
		CRS	23			 SRK10CRS-S	 SRK13CRS-S					
		CSS	23						 SRK19CSS-S		 SRK25CSS-S	
	STANDARD (COOLING)	CR/CRR	24			 SRK09CRR-S	 SRK12CR-S					
		CT/CTR	24			 SRK09CTR-S	 SRK12CT-S					
		CW	25			 SRK10CW-W	 SRK13CW-W	 SRK15CW-W	 SRK18CW-W		 SRK24CW-W	
		CS	26						 SRK18CS-S		 SRK24CS-S	
INVERTER MULTI SPLIT	PREMIUM (COOLING)	SCM	27									

HIGH EFFICIENCY

CONSIDERATION FOR THE ENVIRONMENT

Several radical design changes and engineering developments have brought about a vast improvement in energy efficiency and environmental protection.

Higher Energy class (SEER/SCOP)

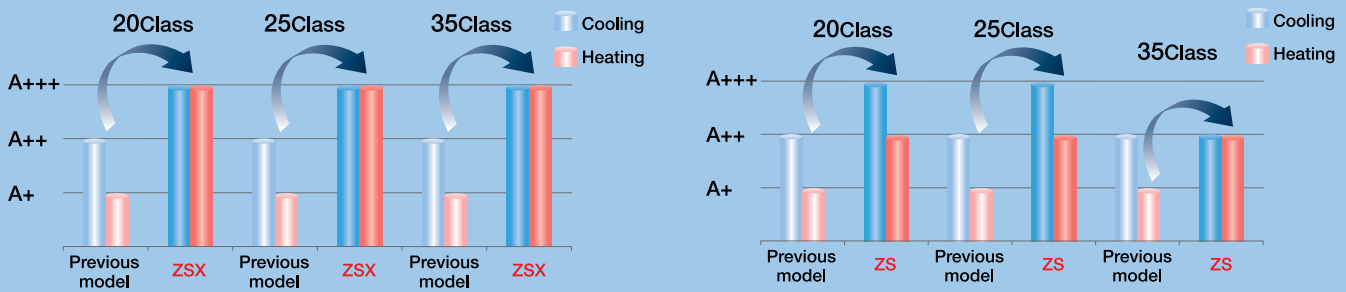

DC PAM INVERTER QUICK & HIGH EFFICIENCY CONTROL

An inverter driven system has a number of performance advantages over a constant speed system. For example, its variable compressor outputs can ensure quick heating after a start up and attain a set temperature more quickly. Then, the air conditioner can slow down its compressor speed to save energy, keeping comfortable conditions. Moreover, the compressor is DC driven, so it provides higher performance.

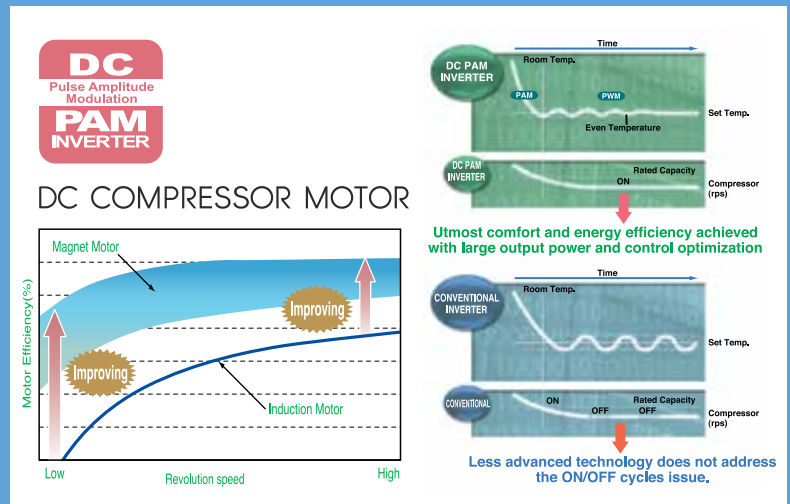

VECTOR INVERTER CONTROL

The inverter control, with the advanced vector control technology, functions at high efficiency.

- Smooth operation from low speed to high speed
- Smooth Sine Voltage Wave form are attained
- Energy efficiency is further improved in low speed range

HIGH EFFICIENCY DC TWIN ROTARY COMPRESSOR

The newly developed DC twin rotary compressor performs highly efficient operation under the wide range conditions from low speed to high speed. Besides low vibration, low sound level and high efficiency can be also achieved by the optimization of mechanical parts dimension and by the application of high power Neodymium motor.



FEATURE ON ALL MODELS OF ZSX SERIES

OUR LATEST Technologies (ZSX series)

[Outdoor unit]

Propeller fan

Matching a propeller fan with a fan motor has been optimized in order to keep the same capacity as that of previous models with less electrical consumption. Synergy effect with leaf grill has increased efficiency by 5% and quietened the sound.



Serration fan

Coated PCB

The printed wiring board of the outdoor unit is coated. It lasts long having a tolerance for humidity.



Heat exchanger

Thanks to changing fin configuration from flat sheet to M shape fin, efficiency has increased by 10%. This high dimensional structure provides optimum balance of heat transfer and airflow.



Heat Transfer Coef. W/m²K



DC Motor

DC fan motor produces high efficiency & high power

Leaf shape grill

The radial shape grill has been developed in order to send airflow efficiently out unit along the grill. Decreasing the load for motor and propeller fan leads to greater energy efficiency and contributes to quieter sound.

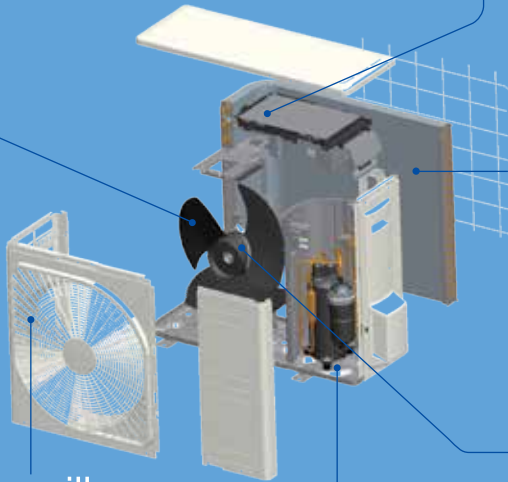

Superior corrosion resistance hot dipping steel sheet



Three Sensors

Control of room temperature and humidity is very important for people to live a comfortable life.

Use of three sensors to control indoor temperature, indoor humidity and outdoor temperature enable unit to obtain optimum air-conditioning.



Sensor for indoor temperature and humidity



Sensor for outdoor temperature

[Indoor unit]

Heat exchanger

Our optimal combination of fin configuration and copper tube has maximized airflow volume without expanding indoor unit's size in width. The heat exchanger efficiency rate has been drastically improved by 33% compared with that of previous models. Fin can maximize airflow volume and save energy simultaneously.

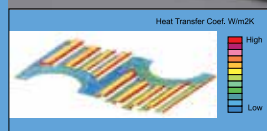

Movable air inlet panel

Applying a movable air inlet panel, minimization of air resistance and advanced design are realized.



* This page is mainly described ZSX series.

AIR FLOW

3D AUTO VERTICAL + HORIZONTAL



MULTI MOTORS MAKE 3 INDEPENDENT CONTROLS

Hi-Power (Quick)

Cool Breeze

Floor Heating

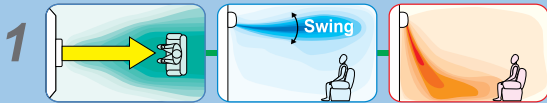

Wide Swing (Every Corner)

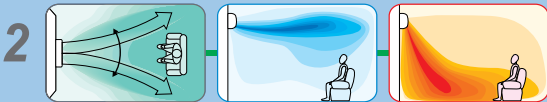

Center (Long)

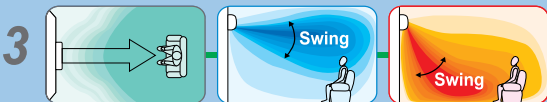

Wide-Air (Equal)



Programmed 3D AUTO

Thanks to automatic control of air flow volume and air flow direction, comfortable air conditioning of the entire room can be done effectively.

The cooled air flows directly to the ceiling in cooling operation mode, not directly at the occupants of the room. Comfort cooled air flow comes via the ceiling like a cool breeze.

In the heating mode, warm air flow can be sent down to the floor directly. The warm air then spreads along the floor achieving optimum comfort.

MANUAL SETTING

By individual control of right and left part of louver, air flow direction from the right part and the left part are controlled individually. Setting the most preferable air flow direction and determining whether direct air flow is required or not at the same time minimizing of energy loss and economical operation has realized.

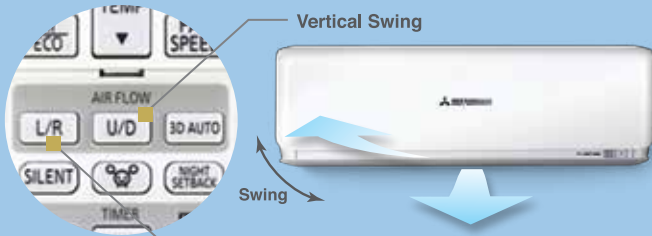

Horizontal Air Scroll 8 Direction Swing

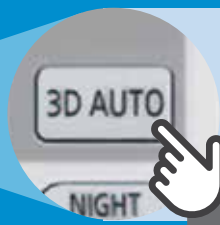
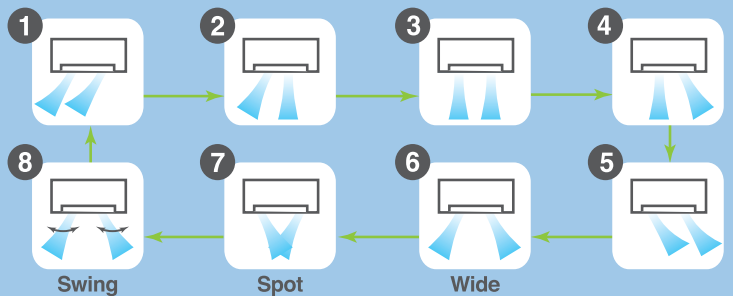

3D AUTO

3D AUTO is one touch programmed and multi motors make three independent air flow controls.

The uniform and quiet airflow can be delivered to every corner of the room, achieving economical operation and minimizing energy loss.

JET FLOW POWERFUL & SILENT AIR FLOW

CFD (computational fluid dynamics), used in blade shape design of jet engines, has been applied to the design of air channels in air conditioners to develop the ideal air channel system (air circulation). The jet air stream generated by this air channel system can bring large volume air without consuming much power. While at the same time, it delivers a uniform gentle breeze to every corner of the room.



(C)Mitsubishi Aircraft Corporation

Comparison with familiar noises in our everyday life

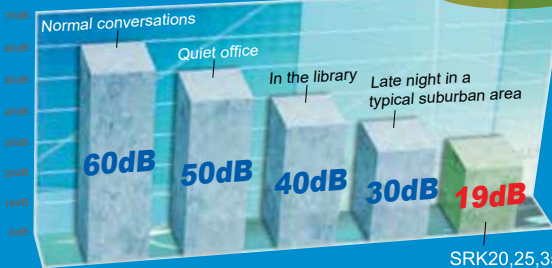

19dB

SRK20,25,35ZSX
SRK20,25,35ZS
(In case of ULo mode)

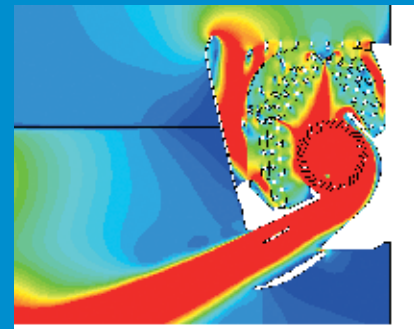

Fast ← → Slow
Colors in the figure show the air speed.

Long Reach Air Flow

Long reach air flow is realized by Jet technology.
Good for large living rooms and shops, which increases comfort.

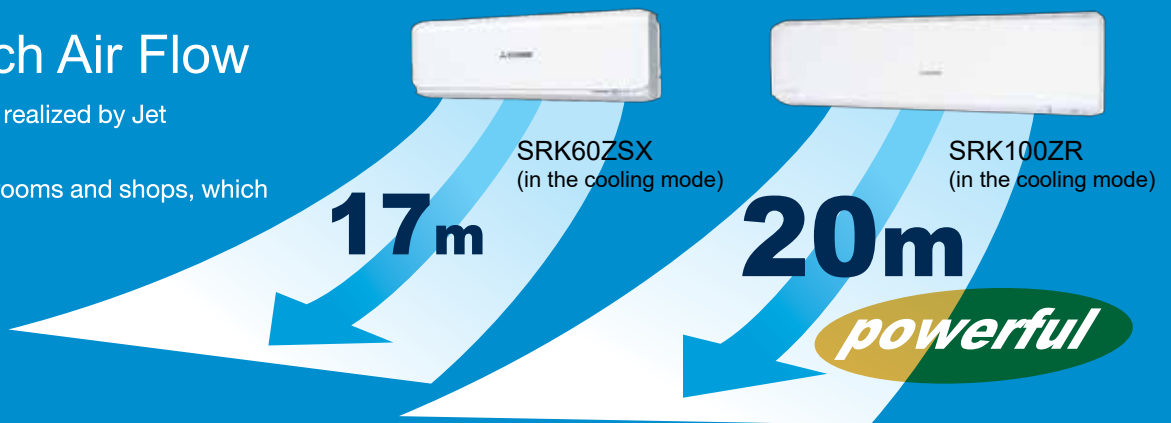

DOUBLE FLAP LARGE & SMALL

Double flaps can control optimized air flow, horizontal and long reach air flow in cooling, strong and downward air flow in heating, which can produce comfort room temperature condition.



ENERGY SAVING

ECO OPERATION

Automatic energy saving control is done by detecting human activity. Human activity is detected by infra-red sensor which is installed in the unit. Air conditioner adjust its cooling/heating capacity according to low/high demand. Economy Cooling operation, Air conditioner controls its capacity lower and goes into energy saving control when low activity is detected. Economy Heating operation, Air conditioner controls its capacity lower and goes into energy saving control when high activity is detected. When the sensor detects that no people are present in the room, the unit will automatically reduce the power used to a moderate level after approximately 15 minutes and return to normal operation once people return to the room.



IN A COOLING OPERATION



It is set to moderate operation when there is little movement in the room.

IN A HEATING OPERATION



It is set to moderate operation when there is a lot of movement in the room.

AUTO OFF

Air conditioner stop operation and goes to "stand-by" mode after 1-hour absence. It turns ON again when human activity is detected within 12-hour, or turned OFF after 12-hour absence. *Can also be set to turn OFF after two hours.

ABSENT



MODERATE OPERATION

It suppresses the power when there is nobody present in the room.

ABSENT 1-HOUR



STAND-BY

You do not need to worry, even if you forget to turn off the power. Air-conditioner keeps stop until human activity is detected.

COME BACK TO ROOM



NORMAL OPERATION TURN ON AGAIN

Automatically operates in the preset mode if you return to the room in twelve hours.

FUZZY AUTO OPERATION

The temperature and humidity sensors check room conditions. The unit automatically controls the operation mode and the setting temperature to operate efficiently. Operation mode and cooling/heating capacity is controlled automatically according to one setting temperature. Fuzzy auto operation offers automatic comfort temperature control even if weather condition changes quickly.

* This page is mainly described ZSX series.

COMFORT & CONVENIENCE

HIGH POWER OPERATION



IN A COOLING OPERATION

This operation mode delivers powerful cool air to cool the room quickly. It blows powerful cool air when you want to be cooled down after bathing or returning home on a hot summer day so that you can enjoy a cool sensation immediately. The air conditioner automatically returns to the previous operation mode in 15 minutes to prevent the room from being cooled excessively.

IN A HEATING OPERATION

This operation mode warms the whole room from the vicinity of the air conditioner to your feet. It warms up the room promptly when you want to be warmed such as getting out of bed or returning home during the winter seasons. The air conditioner automatically returns to the previous operation mode in 15 minutes to prevent the room from being warmed excessively.

SILENT OPERATION



When Silent operation is set, the maximum pressure level of the outdoor unit will be 3dB(A) lower than standard nominal level (45dB(A) or less). The compressor speed is set at a lower range than that of nominal operation, operating at 60% of nominal capacity. Maximum fan speed of outdoor unit is set lower than nominal operation.

NIGHT SETBACK OPERATION



During cold seasons, room temperatures can be maintained at a comfortable level even while the room is unattended. The air conditioner keeps the temperature at 10°C.

COMFORT & CONVENIENCE

WEEKLY TIMER OPERATION

Up to 4 programs with timer operation (ON-TIMER / OFF-TIMER) are available for each day of the week. Maximum 28 programs per week can be set. Once set, the timer operation will repeat the same program every week unless otherwise canceled.

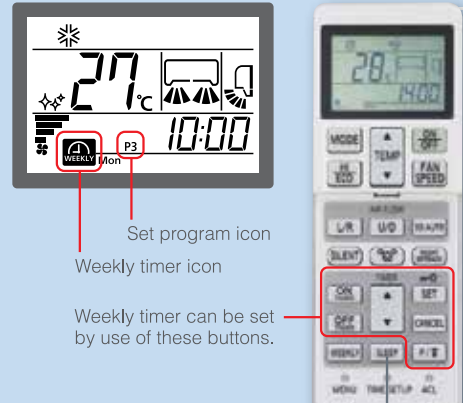

SLEEP TIMER

Too much cooling/heating is not necessary when people go to sleep. This function achieves moderate cooling/heating by adjusting its capacity and more energy saving as well.

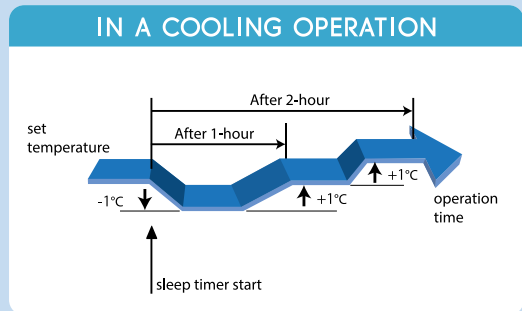
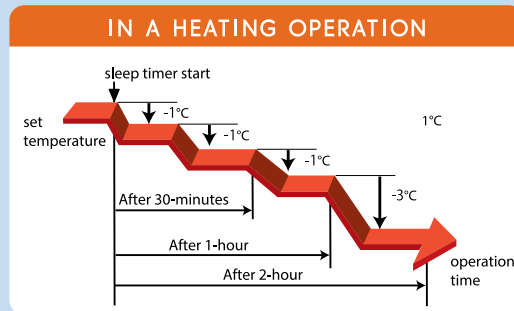

PRE-OPERATION TO COMFORT START-UP

Air conditioner controls room temperature to achieve comfort at the "set time" by 60 minutes pre-operation. This is convenient when you wake up and return home at a predetermined time. In ON-TIMER operation, the unit starts the operation a little earlier, so that the room can approach optimum temperature at ON time.

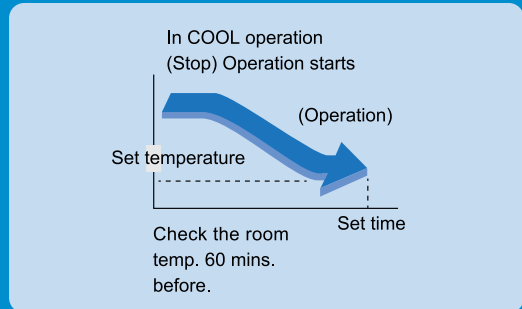

PRESET OPERATION

The Preset Operation features allows customised temperature and airflow settings, which will deliver ultimate comfort with one simple touch of the button.

CHILD LOCK

Blocks the unit preventing tampering and inadvertent operations. This function is useful for families with young children.

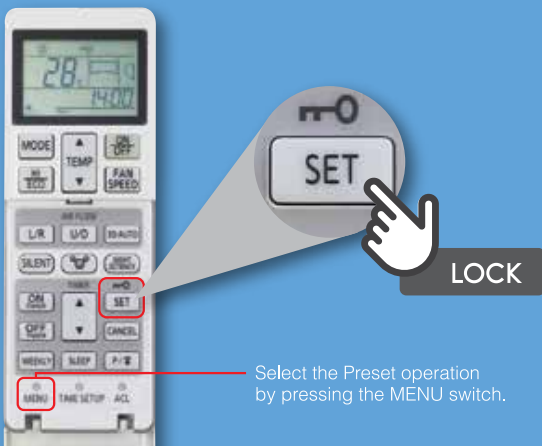

LED BRIGHTNESS ADJUSTMENT

Brightness of the LED display can be adjusted to suit. (Applied for ZSX & ZS series)



* This page is mainly described ZSX series.

CLEAN AIR

THIS IS THE ORIGINAL AND ONLY TECHNOLOGY TO CONTROL THE TEMPERATURE AND HUMIDITY FOR INACTIVATING ALLERGENS

This can be activated by pressing the "allergen" button on the remote control and lasts 90 minutes before stopping automatically. It neutralizes all the bacteria collected on the surface of the anti-allergenic filter thanks to its sophisticated interaction between temperature and humidity controls.



PUSH ALLERGEN MODE

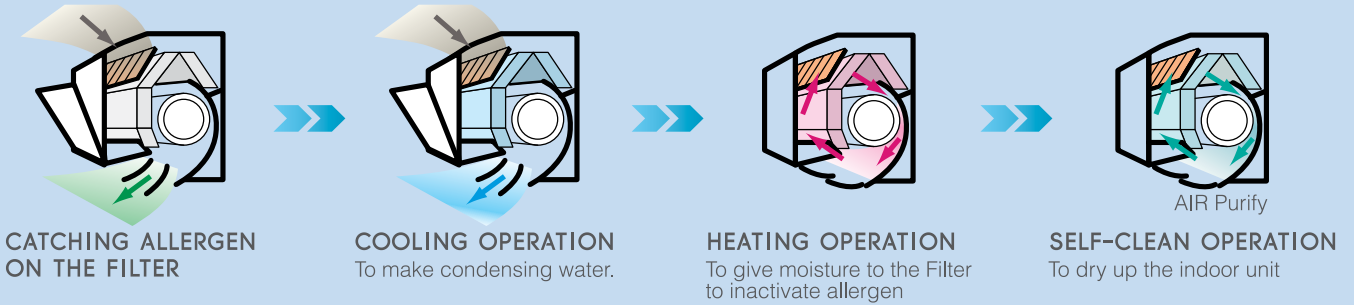

SELF CLEAN OPERATION

Self clean operation is operated for 2 hours after the unit has stopped its normal operation. The indoor unit is dried up and the growth of mold is restrained. Users can select whether this mode is utilized or not.

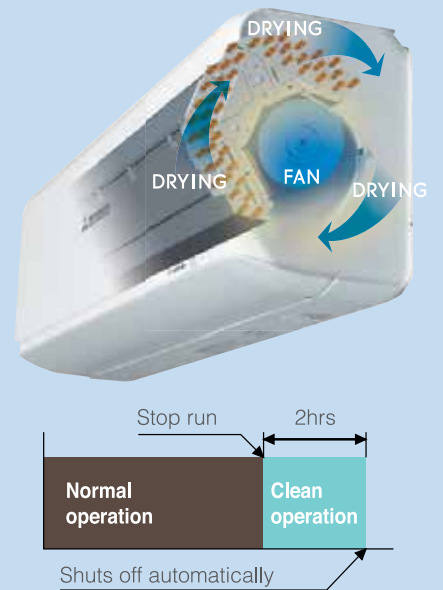
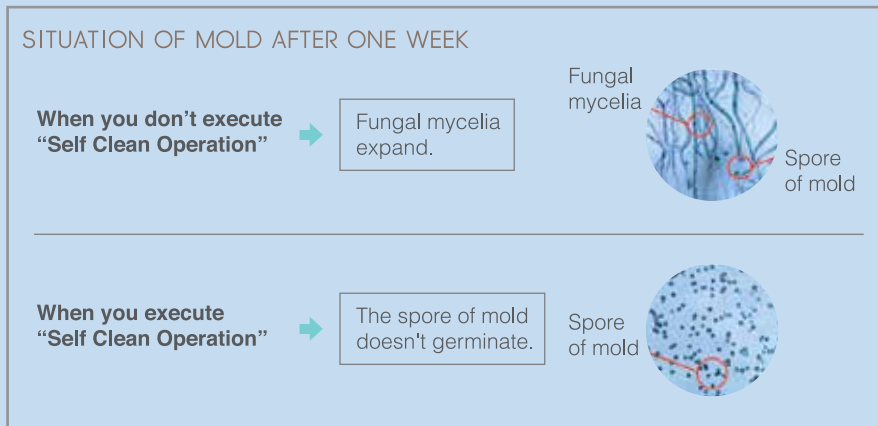

ALLERGEN CLEAR FILTER

**ENZYME + UREA
DEACTIVATES ALLERGENS
AND BACTERIA.**



The allergen clear filter breaks down the pollen^{*1}, lice^{*1}, and allergens that live on cat skins, etc. and deactivates them. The secret of deactivation is the Enzyme-urea compound. It deactivates not only allergens but also all kinds of bacteria^{*2}, molds and viruses^{*3}. Even if allergens and bacteria, etc. fly off the filter, they are deactivated, so the air in your room is kept fresh.

*1 Test method:ELISA colorimetric method Laboratory:Independent administrative agency national hospital mechanism Sagamihara Hospital, No.1536

*2 Test method:ELISA colorimetric method / ELISA fluorescent method Laboratory:Independent administrative agency national hospital mechanism Sagamihara Hospital, No.1536

*3 Test method:TCID (Infection value 50%) Laboratory:Foundation of Kitazato Environmental Science Center, No.15-0145

STRUCTURE OF PREVENTING DIRT

ALWAYS KEEPING THE INDOOR UNIT CLEAN

The fan has undergone anti-microbial treatment to resist mold and germs, making the system clean and safe. Foul odours and molds, etc. which can occur when an air conditioning system is not in operation are prevented.

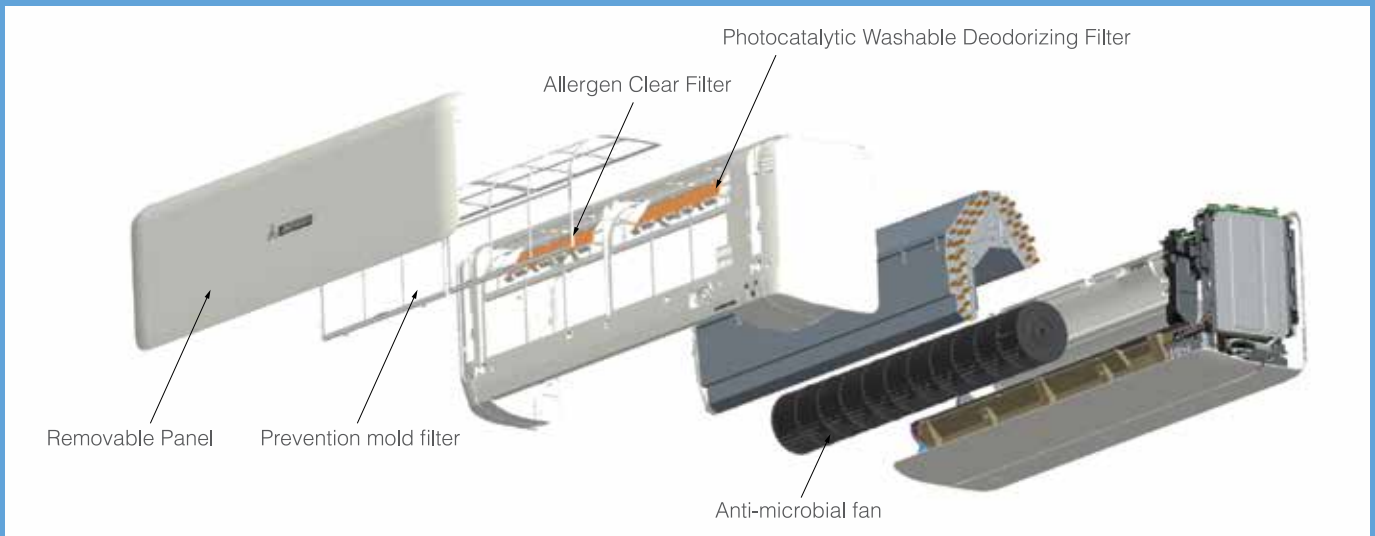

ASPERGILUS NIGER IFO6341

TESTING AUTHORITY: JAPAN FOOD ANALYSIS CENTER

Test Report No.: 104034022-002

Tests were conducted with reference to the antimicrobial strength tests in JIS Z 2801 2000 "Antimicrobial Products-Antimicrobial Test Method" -5.2 Antimicrobial Effects: Test Methods for Plastic Products, etc



In tests conducted at the Mitsubishi Heavy Industries Nagoya Research Lab, 24 hrs after contact with bacteria, cultured on agar media.

SURE TO DESTROY FUNGI AND BACTERIA, ALSO EFFECTIVE ON VIRUSES AND ALLERGENIC COMPOUNDS (CAT HAIR, DUST MITE, POLLEN ETC.)

NATURAL ENZYME FILTER

The first release in this range of the enzyme-sterilizing filter



Enzymes used in these filters are naturally occurring lytic enzymes. The lytic enzymes attack cell walls of microorganisms trapped on a filter and destroy them and doing so, have a powerful sterilizing which will effectively decrease the number of molds and bacteria. Natural Enzyme Filter will clean and sanitize air passing through it to keep air in the room clean and safe.

PHOTOCATALYTIC WASHABLE DEODORIZING FILTER

It will keep the air fresh by deodorizing the molecules causing odour. Its deodorizing power can be restored by washing with water and drying under the sun, as such it is a Recycling deodorizing filter capable of repeat use.

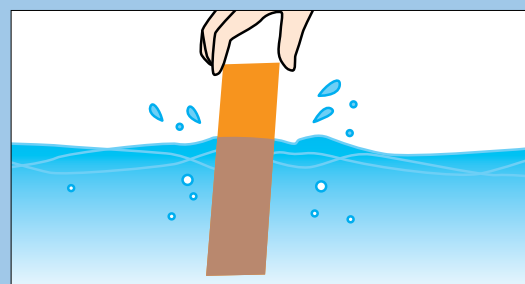

USED IN MODELS

FILTER	INDOOR UNIT	SRK-ZSX	SRK-ZS	SRK-ZR
Allergen Clear Filter		1pc	1pc	1pc
Photocatalytic Washable Deodorizing Filter		1pc	1pc	1pc

FUNCTIONS

ENERGY SAVING



FUZZY AUTO MODE
Automatically, the unit determines its operating mode and temperature setting based on a fuzzy calculation.



ECO OPERATION
Room temperature and humidity are monitored using a sensor to automatically control the operation. In tandem with the human sensor, the system enables a energy saving mode while maintaining comfort.



AUTO OFF
Stops the operation automatically when there are no people activity detected in the room for a certain period of time.



MOTION SENSOR
This sensor detects human motion activity and movement and inhibits unnecessary operation when not required.



ECONOMY MODE
The unit realizes effective energy saving operation, while still keeping a comfortable cooling and heating condition.

AIR FLOW



JET FLOW
Aircraft technology is used to component design the airflow system of the air conditioner.



MEMORY FLAP
While the flap is swinging, it can be stopped at any angle desired. The flap returns to the position that it was in when operation last stopped.



AIR OUTLET SELECTION
Both lower and upper air outlets and upper air outlet can be selected.



3D AUTO
You can choose the best cooling or heating pattern by only pushing one button.



UP/DOWN FLAP SWING
Flap moves up and down continuously. The Up/Down flap swing can be fixed at the preferred operation angle.



LONG REACH AIR FLOW
With our remarkable jet flow technology, it allows at once long reach air flow (18m) and minimum power consumption.



AUTO FLAP MODE
Whatever the operating mode is, the unit automatically selects the optimal angle.

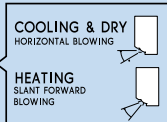

RIGHT/LEFT LOUVER SWING
Louver moves right and left continuously. The Right/Left louver swing can be fixed at the preferred operation angle.



MOVABLE AIR INLET PANEL
Applying a movable air inlet panel, minimization of air resistance and advanced design are realized.

CLEAN OPERATION & FILTER



ALLERGEN CLEAR OPERATION
The system is equipped to suppress the influence of the allergen caught by the filter by controlled the temperature and humidity.



PHOTOCATALYTIC WASHABLE DEODORIZING FILTER
It keeps air fresh by deodorizing the molecules causing odor. The deodorizing ability can be easily restored simply by cleaning and exposing to the sunlight.



DETACHABLE INDOOR AIR INLET PANEL
The air inlet panel on the indoor unit opens and closes easily, making filter cleaning simple. The suction panel can also be removed.



SELF CLEAN OPERATION
The operation is operated for 2 hours after the unit has stopped its normal operation. The indoor unit is dried up and growth of mold is restrained.



NATURAL ENZYME FILTER
Enzymes used in the filter are naturally occurring lytic enzymes which attack cell walls of microorganisms trapped on the filter and destroy them.



ONE ACTION FILTER
For easy maintenance filter can be taken off and put on easily by just 1 slide action.



ALLERGEN CLEAR FILTER
The filter breaks down the pollen, lice, and all allergens that live on cat skins, etc. and deactivates them.



ANTI-MICROBIAL BLOWER FAN
The blower fan has undergone anti-microbial treatment to resist mold and germs, making the system clean and safe. Foul odors and molds, etc. which can occur when an air conditioning system is not in operation are prevented.



ONE ACTION FILTER
For easy maintenance filter can be taken off and put on easily by just 1 slide action.

COMFORT & CONVENIENCE



DRY OPERATION
The unit dehumidifies the room by intermittent cooling operation.



WEEKLY TIMER
Up to 4 programs with timer operation (ON-TIMER/OFF-TIMER) are available for each day of the week. MAX 28 programs per week can be set.



COMFORT START-UP
In ON-TIMER operation, the unit automatically starts the operation a little earlier, so that the room can approach optimum temperature at ON time.



POSITIONING OF INSTALLATION
You can Set the left-right air flow directions when you installed the air conditioner near the Side Wall by remote controller operation.



HIGH POWER OPERATION
The unit can operate continuously in "HI POWER" mode for 15 minutes. This mode is convenient to reach the desired temperature quickly.



24-HOUR ON/OFF PROGRAMMABLE TIMER
By combining a start timer with a stop timer, you can register two timer operations a day. Once set, timers will faithfully start or stop the system at a specified time of the day repeatedly.



PRESET OPERATION
The desired preset operation mode can be enabled with a single touch of a button.



AUTOMATIC OPERATION
The air conditioner automatically selects from among heating, cooling and dry operations.



SILENT OPERATION
The sound level of outdoor units is at least 3 dB(A) lower than the nominal level.



SLEEP TIMER
The room temperature is automatically controlled during the set sleep mode period, ensuring that room temperature will not get too cold or too hot.



CHILD LOCK
Blocks the unit preventing tampering and inadvertent operations. This function is useful for families with young children.



COMPACT SIZE
Thanks to this new fin configuration applied to "Heavy Duty Micro", the desired result is its compact size.



NIGHT SETBACK
During cold seasons, room temperatures can be maintained at a comfortable level even while the room is unattended. The air conditioner keeps the temperature at 10°C.



ON/OFF TIMER
The unit will start and stop the operation automatically at the set time.



LED BRIGHTNESS ADJUSTMENT
Brightness of the LED display can be adjusted to suit.

OTHERS



MICROCOMPUTER-OPERATED DEFROSTING
This mode automatically eliminates frost, and helps minimize excessive operation in other modes.



AUTO RESTART FUNCTION
Power blackout auto restart function is a function that records the operational status of the air-conditioner immediately prior to it being switched off by a power cut, and then automatically resumes operations at that point after the power has been restored.



24-HOUR ION
Tourmaline-coated sheet generates negative ions around the clock. Even when the air conditioner is not running, it generates as many negative ions as a forest, stream or fall does, allowing you to experience them without incurring any electricity charges.



DC PAM INVERTER
An inverter driven system has a number of performance advantages over a constant speed system. For example, its variable compressor outputs can ensure quick heating after a startup and attain a set temperature more quickly. Their conditioner can then slow down its compressor speed to save energy, keeping comfortable conditions. Moreover, the compressor is DC driven, so it provides higher performance.



SELF-DIAGNOSTIC FUNCTION
In the case that the air conditioner malfunctions, an internal micro-computer automatically runs a self-diagnosis. (Inspection and repair should be performed by authorized dealers.)



BACK-UP SWITCH
On the main unit, there is a backup on/off switch, which is useful when you can't use remote control, or batteries are flat.



LUMINOUS BUTTON
With wireless "Luminous" remote controls that even "glow in the dark", it is possible to operate all desired functions of the unit with the click of a button.

		ZSX	ZS	ZR	ZSP	YVS	YW	YL/MLV	YN	CVS	CRS	CSS	CR/CRR	CT/CTR	CW	CS	SRF	SRR	FDTC ³	FDUM ³	FDE ³	
ENERGY SAVING	FUZZY AUTO MODE	●	●	●	●	●	●	●	●	●	●	●	●	●	●	●	●	●	●	●	●	
	MOTION SENSOR	●																				
	ECO OPERATION	●																				
	ECONOMY MODE		●	●	●	●	●	●	●	●	●	●	●	●	●	●	●	●	●	●	●	
AUTO OFF	●																					
AIR FLOW	JET FLOW	●	●	●	●	●	●	●	●	●	●	●	●	●	●	●						
	3D AUTO	●	●	●		●		●		●	●	●										
	AUTO FLAP MODE	●	●	●	●	●	●	●	●	●	●	●	●	●	●	●	●			●	●	
	MEMORY FLAP	●	●	●	●	●	●	●	●	●	●	●	●	●	●	●	●	●		●	●	
	UP/DOWN FLAP SWING	●	●	●	●	●	●	●	●	●	●	●	●	●	●	●	●	●		●	●	
	RIGHT/LEFT LOUVER SWING	●	●	●		●		●		●	●	●										
	AIR OUTLET SELECTION																	●				
	LONG REACH AIR FLOW	●		●							●		●				●					
	MOVABLE AIR INLET PANEL	●																				
	CLEAN OPERATION & FILTER	ALLERGEN CLEAR OPERATION ^{*1}	●	●	●																	
SELF CLEAN OPERATION		●	●	●	●	●	●	●	●	●	●	●	●	●	●	●	●	●				
ALLERGEN CLEAR FILTER		●	●	●																		
PHOTOCATALYTIC WASHABLE DEODORIZING FILTER		●	●	●							●	●	●					●				
NATURAL ENZYME FILTER						●		●		●	●	●						●				
ANTI-MICROBIAL BLOWER FAN		●	●	●		●	●	●		●		●				●						
DETACHABLE INDOOR AIR INLET PANEL		●	●	●	●	●	●	●		●	●	●		●	●	●	●	●				
ONE ACTION FILTER									●				●									
COMFORT & CONVENIENCE	DRY OPERATION	●	●	●	●	●	●	●	●	●	●	●	●	●	●	●	●	●	●	●	●	
	HIGH POWER OPERATION	●	●	●	●	●	●	●	●	●	●	●	●	●	●	●	●	●	●	●	●	
	SILENT OPERATION ^{*1}	●	●	●														●	●			
	NIGHT SETBACK	●	●	●														●	●			
	WEEKLY TIMER	●	●	●														●	●			
	24-HOUR ON/OFF PROGRAMMABLE TIMER	●	●	●	●	●	●	●	●	●	●	●	●	●	●	●	●	●	● ^{*2}	●	●	●
	SLEEP TIMER	●	●	●	●	●	●	●	●	●	●	●	●	●	●	●	●	●	●	●	●	●
	ON/OFF TIMER	●	●	●	●	●	●	●	●	●	●	●	●	●	●	●	●	●	●	●	●	●
	COMFORT START-UP	●	●	●	●	●	●	●	●	●	●	●	●	●	●	●	●	●	●	●	●	●
	PRESET OPERATION	●	●			●																
	CHILD LOCK	●	●	●		●												●	●			
	LED BRIGHTNESS ADJUSTMENT	●	●			●																
	POSITIONING OF INSTALLATION	●	●	●		●		●		●	●	●										
	AUTOMATIC OPERATION	●	●	●	●	●	●	●	●	●	●	●	●	●	●	●	●	●	●	●	●	●
	COMPACT SIZE				●		●		●				●	●	●							
OTHERS	MICROCOMPUTER-OPERATED DEFROSTING	●	●	●	●													●	●	●	●	
	SELF-DIAGNOSTIC FUNCTION	●	●	●	●	●	●	●	●	●	●	●	●	●	●	●	●	●	●	●	●	
	AUTO RESTART FUNCTION	●	●	●	●	●	●	●	●	●	●	●	●	●	●	●	●	●	●	●	●	
	BACK-UP SWITCH	●	●	●	●	●	●	●	●	●	●	●	●	●	●	●	●	●	●	●	●	
	24-HOUR ION					●	●	●	●	●	●	●		●	●	●	● ^{*4}					
	LUMINOUS BUTTON	●	●	●	●	●	●	●	●	●	●	●	●	●	●	●	●	●	●	●	●	●
	DC PAM INVERTER	●	●	●	●	●	●	●	●	●								●	●	●	●	●

*1 In case of Multi-split system, is not available.

*2 When using Wired remote control.

*3 When using Wireless remote control.

*4 Only SRK24CS-S.

INVERTER SINGLE SPLIT DIAMOND (COOLING & HEATING) ZSX SERIES



Inverter



REFRIGERANT PIPE LENGTH

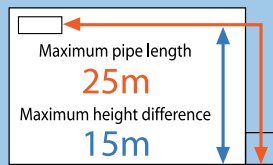

SRK20ZSX-S
SRK25ZSX-S
SRK35ZSX-S

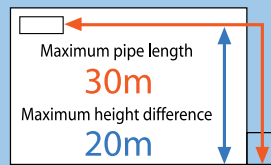

SRK50ZSX-S
SRK60ZSX-S



SRC20ZSX-S, SRC25ZSX-S
SRC35ZSX-S, SRC50ZSX-S
SRC60ZSX-S

FUNCTIONS

ENERGY SAVING



AIR FLOW



CLEAN OPERATION & FILTER



COMFORT & CONVENIENCE



OTHERS



SPECIFICATIONS

			ZSX SERIES					
			SRK20ZSX-S	SRK25ZSX-S	SRK35ZSX-S	SRK50ZSX-S	SRK60ZSX-S	
Indoor			SRK20ZSX-S	SRK25ZSX-S	SRK35ZSX-S	SRK50ZSX-S	SRK60ZSX-S	
Outdoor			SRC20ZSX-S	SRC25ZSX-S	SRC35ZSX-S	SRC50ZSX-S	SRC60ZSX-S	
Power source			1Phase, 220-240V, 50Hz	1Phase, 220-240V, 50Hz	1Phase, 220-240V, 50Hz	1Phase, 220-240V, 50Hz	1Phase, 220-240V, 50Hz	
Capacity	Cooling	kW	2.0	2.5	3.5	5.0	6.1	
	Heating	kW	2.7	3.2	4.3	6.0	6.8	
Power consumption		Cooling/Heating kW	0.32/0.47	0.44/0.59	0.78/0.90	1.30/1.36	1.81/1.67	
EER/COP		Cooling/Heating W/W	6.25/5.74	5.68/5.42	4.49/4.78	3.85/4.41	3.37/4.07	
Inrush current /Max. current		A	2.5/9.0	3.0/9.0	4.3/9.0	5.0/15.0	5.0/15.0	
Indoor unit	Airflow rate (Hi/Me/Lo)	Cooling	m ³ /min	11.3/9.1/6.0	12.2/10.0/6.7	13.1/10.8/7.3	14.3/12.4/7.8	16.3/13.4/8.9
		Heating	m ³ /min	12.2/10.3/7.2	12.8/11.0/7.8	13.9/11.8/8.6	17.3/14.3/9.8	17.8/13.7/10.9
	Sound pressure level (Hi/Me/Lo)	Cooling	dB(A)	38/31/24	39/33/25	43/35/26	44/39/31	46/41/33
		Heating	dB(A)	38/32/25	40/34/27	41/35/28	46/41/33	46/42/34
	Exterior dimensions (HxWxD)		mm	305 x 920 x 220	305 x 920 x 220	305 x 920 x 220	305 x 920 x 220	305 x 920 x 220
Net weight		kg	13	13	13	13	13	
Outdoor unit	Airflow rate	Cooling/Heating	m ³ /min	31/31	31/31	36/31	39/33	41/39
	Sound pressure level	Cooling/Heating	dB(A)	43/44	44/45	48/47	50/49	52/52
	Exterior dimensions (HxWxD)		mm	640 x 800(+71) x 290	640 x 800(+71) x 290	640 x 800(+71) x 290	640 x 800(+71) x 290	640 x 800(+71) x 290
	Net weight		kg	43	43	43	45	45
Refrigerant type	type		R410A	R410a	R410a	R410a	R410a	
	charge amount (Pre-charge pipe length)	kg (m)	1.45 (15m)	1.45 (15m)	1.45 (15m)	1.50 (15m)	1.50 (15m)	
Piping size (Liquid/Gas)		mm	φ6.35 / φ9.52	φ6.35 / φ9.52	φ6.35 / φ9.52	φ6.35 / φ12.7	φ6.35 / φ12.7	
Refrigerant line (one way) length		m	Max.25	Max.25	Max.25	Max.30	Max.30	
Vertical height differences		Outdoor is higher /lower	m	Max.15 /Max.15	Max.15 /Max.15	Max.15 /Max.15	Max.20 /Max.20	Max.20 /Max.20
Outdoor operating temperature range		Cooling	°C	-15~46	-15~46	-15~46	-15~46	-15~46
		Heating	°C	-20~24	-20~24	-20~24	-20~24	-20~24

INVERTER SINGLE SPLIT PREMIUM (COOLING & HEATING) ZS SERIES



Pure White (-S)



Inverter

FUNCTIONS

ENERGY SAVING



AIR FLOW



CLEAN OPERATION & FILTER



COMFORT & CONVENIENCE



OTHERS



Black & White (-SB)



Titanium (-ST)

SPECIFICATIONS

		ZS SERIES					
		SRK20ZS-S	SRK25ZS-S	SRK35ZS-S	SRK50ZS-S		
Indoor		SRC20ZS-S					
Outdoor		SRC25ZS-S					
Power source		1Phase, 220-240V, 50Hz					
Capacity	Cooling	kW	2.0	2.5	3.5	5.0	
	Heating	kW	2.7	3.2	4.0	5.8	
Power consumption		Cooling/Heating	kW	0.44/0.62	0.62/0.80	1.01/1.00	1.56/1.59
EER/COP		Cooling/Heating	W/W	4.55/4.35	4.03/4.00	3.47/4.00	3.21/3.45
Inrush current/Max.current		A	3.2/9.0	4.0/9.0	4.9/9.0	7.3/14.5	
Indoor unit	Airflow rate (Hi/Me/Lo)	Cooling	m ³ /min	9.3/7.0/5.9	9.9/8.0/5.9	11.3/8.7/5.6	12.1/9.9/7.4
		Heating	m ³ /min	10.0/8.5/6.5	11.3/8.7/6.7	12.3/11.0/7.0	13.9/11.2/9.1
	Sound pressure level (Hi/Me/Lo)	Cooling	dB(A)	34/25/22	36/28/23	40/30/26	45/36/28
		Heating	dB(A)	36/29/23	39/30/24	41/36/25	45/37/31
	Exterior dimensions (HxWxD)	mm	290 x 870 x 230	290 x 870 x 230	290 x 870 x 230	290 x 870 x 230	
Net weight	kg	9	9	9	10		
Outdoor unit	Airflow rate	Cooling/Heating	m ³ /min	27/23	27/23	31/27	32/32
		Sound pressure level	Cooling/Heating	dB(A)	45/45	46/46	50/48
	Exterior dimensions (HxWxD)	mm	540 x 780 (+62) x 290	540 x 780 (+62) x 290	540 x 780 (+62) x 290	595 x 780 (+62) x 290	
	Net weight	kg	31	31	34	36	
	Refrigerant type	type	R410A				
	charge amount (Pre-charge pipe length)	kg (m)	0.75 (15m)	0.75 (15m)	0.95 (15m)	1.25 (15m)	
Piping size (Liquid/Gas)		mm	φ6.35 / φ9.52	φ6.35 / φ9.52	φ6.35 / φ9.52	φ6.35 / φ12.7	
Refrigerant line (one way) length		m	Max.20	Max.20	Max.20	Max.25	
Vertical height differences		Outdoor is higher / lower	m	Max.10 / Max.10	Max.10 / Max.10	Max.10 / Max.15	
Outdoor operating temperature range		Cooling	°C	-15~46	-15~46	-15~46	-15~46
		Heating	°C	-15~24	-15~24	-15~24	-15~24

REFRIGERANT PIPE LENGTH

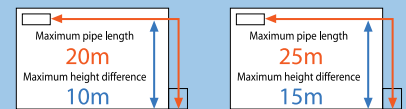

SRK20ZS-S
SRK25ZS-S
SRK35ZS-S

SRK50ZS-S



SRC20ZS-S
SRC25ZS-S
SRC35ZS-S



SRC50ZS-S

INVERTER SINGLE SPLIT PREMIUM (COOLING & HEATING) ZR SERIES



Inverter

FUNCTIONS

ENERGY SAVING



AIR FLOW



CLEAN OPERATION & FILTER



COMFORT & CONVENIENCE



OTHERS



REFRIGERANT PIPE LENGTH

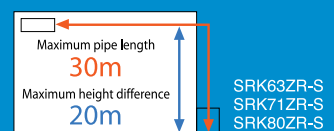

SRK63ZR-S
SRK71ZR-S
SRK80ZR-S



SRC63ZR-S



SRC71ZR-S
SRC80ZR-S

SPECIFICATIONS

		ZR SERIES				
Indoor		SRK63ZR-S				
Outdoor		SRC63ZS-S				
Power source		1Phase, 220-240V, 50Hz				
Capacity	Cooling	kW	6.3	7.1	8.0	
	Heating	kW	7.1	8.0	9.0	
Power consumption		Cooling/Heating	kW	1.85/1.74	2.05/2.06	2.35/2.40
EER/COP		Cooling/Heating	W/W	3.41/4.08	3.46/3.88	3.40/3.75
Inrush current/Max.current		A	8.5/14.5	9.6/17.0	11.1/17.0	
Indoor unit	Airflow rate (Hi/Me/Lo)	Cooling	m ³ /min	20.5/18.1/15.7	20.5/18.6/16.2	23.5/20.2/17.5
		Heating	m ³ /min	23.5/19.0/16.5	25.5/19.9/17.3	26.5/21.3/18.4
	Sound pressure level (Hi/Me/Lo)	Cooling	dB(A)	44/39/35	44/41/37	47/44/39
		Heating	dB(A)	44/38/34	46/39/35	47/41/36
	Exterior dimensions (HxWxD)	mm	339 x 1197 x 262	339 x 1197 x 262	339 x 1197 x 262	
Net weight	kg	15	15	16		
Outdoor unit	Airflow rate	Cooling/Heating	m ³ /min	41/41	55/43	63/49
		Sound pressure level	Cooling/Heating	dB(A)	54/54	53/51
	Exterior dimensions (HxWxD)	mm	640 x 800 (+70) x 290	750 x 880 (+88) x 340	750 x 880 (+88) x 340	
	Net weight	kg	45	57	58.5	
	Refrigerant type	type	R410A			
	charge amount (Pre-charge pipe length)	kg (m)	1.55 (15m)	1.80 (15m)	1.90 (15m)	
Piping size (Liquid/Gas)		mm	φ6.35 / φ12.7	φ6.35 / φ15.88	φ6.35 / φ15.88	
Refrigerant line (one way) length		m	Max.30	Max.30	Max.30	
Vertical height differences		Outdoor is higher / lower	m	Max.20 / Max.20	Max.20 / Max.20	
Outdoor operating temperature range		Cooling	°C	-15~46	-15~46	-15~46
		Heating	°C	-15~24	-15~24	-15~24

INVERTER SINGLE SPLIT STANDARD (COOLING & HEATING) ZSP SERIES



REFRIGERANT PIPE LENGTH

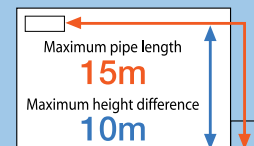

SRC25ZSP-S, SRK35ZSP-S

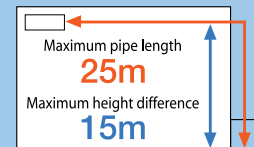

SRK45ZSP-S

FUNCTIONS

ENERGY SAVING



AIR FLOW



CLEAN OPERATION & FILTER



COMFORT & CONVENIENCE



OTHERS



SPECIFICATIONS

			ZSP SERIES			
Indoor			SRK25ZSP-S	SRK35ZSP-S	SRK45ZSP-S	
Outdoor			SRC25ZSP-S	SRC35ZSP-S	SRC45ZSP-S	
Power source			1Phase, 220-240V, 50Hz			
Capacity	Cooling	kW	2.5	3.2	4.5	
	Heating	kW	2.8	3.6	5.0	
Power consumption	Cooling / Heating	kW	0.780 / 0.755	0.995 / 0.995	1.495 / 1.385	
EER/COP	Cooling / Heating	W/W	3.21 / 3.71	3.22 / 3.62	3.01 / 3.61	
Inrush current / Max. current		A	3.9 / 9.0	4.9 / 9.0	7.0 / 14.0	
Indoor unit	Airflow rate (Hi/Me/Lo)	Cooling	m ³ /min	10.0 / 7.3 / 4.2	9.5 / 6.8 / 4.2	9.0 / 7.2 / 3.8
		Heating	m ³ /min	9.5 / 7.3 / 5.2	9.6 / 7.4 / 5.5	12.0 / 9.2 / 6.2
	Sound pressure level (Hi/Me/Lo)	Cooling	dB(A)	45 / 34 / 23	45 / 36 / 23	44 / 39 / 24
		Heating	dB(A)	43 / 34 / 26	44 / 36 / 28	48 / 41 / 30
	Exterior dimensions (HxWxD)		mm	267 x 783 x 210	267 x 783 x 210	267 x 783 x 210
Net weight		kg	7	7	7	
Outdoor unit	Airflow rate	m ³ /min	26 / 19	25 / 20	35 / 33	
	Sound pressure level	dB(A)	47 / 45	47 / 48	51 / 51	
	Exterior dimensions (HxWxD)		mm	540 x 645(+57) x 275	540 x 645(+57) x 275	595 x 780(+62) x 290
	Net weight		kg	25	27	40
Refrigerant type	type		R410A	R410A	R410A	
	charge amount (Pre-charge pipe length)	kg (m)	0.65 (10m)	0.81 (15m)	1.20 (15m)	
Piping size (Liquid/Gas)		mm	φ6.35 / φ9.52	φ6.35 / φ9.52	φ6.35 / φ12.7	
Refrigerant line (one way) length		m	Max.15	Max.15	Max.25	
Vertical height differences	Outdoor is higher / lower	m	Max.10 / Max.10	Max.10 / Max.10	Max.15 / Max.15	
Outdoor operating temperature range	Cooling	°C	-15~46	-15~46	-15~46	
	Heating	°C	-15~24	-15~24	-15~24	

INVERTER SINGLE SPLIT DELUXE (COOLING) YVS SERIES



Inverter



SRK10YVS-W, SRK13YVS-W, SRK18YVS-W



SRK24YVS-W

FUNCTIONS

ENERGY SAVING



AIR FLOW

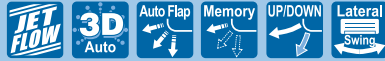

CLEAN OPERATION & FILTER



COMFORT & CONVENIENCE



OTHERS



REFRIGERANT PIPE LENGTH

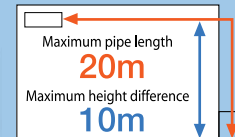

SRK10YVS-W, SRK13YVS-W SRC10YVS-W, SRC13YVS-W

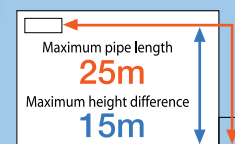

SRK18YVS-W



SRC10YVS-W, SRC13YVS-W



SRC18YVS-W

REFRIGERANT PIPE LENGTH

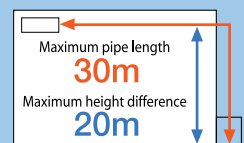

SRK24YVS-W



SRC24YVS-W

SPECIFICATIONS

			YVS SERIES			
Indoor			SRK10YVS-W	SRK13YVS-W	SRK18YVS-W	SRK24YVS-W
Outdoor			SRC10YVS-W	SRC13YVS-W	SRC18YVS-W	SRC24YVS-W
Power source			1Phase, 220-240V, 50Hz	1Phase, 220-240V, 50Hz	1Phase, 220-240V, 50Hz	1Phase, 220-240V, 50Hz
Capacity	Cooling	kW	2.5	3.5	5.2	7.1
		Btu/h	8,530	11,940	17,740	24,220
Power consumption		Cooling kW	0.51	0.82	1.39	1.84
COP		Cooling W/W	4.90	4.27	3.74	3.86
Inrush current / Max. current		A	2.6 / 9.0	3.9 / 9.0	5.0 / 14.5	17.0
Indoor unit	Airflow rate (Hi/Me/Lo)	m ³ /min	10.9 / 8.4 / 5.3	12.3 / 9.1 / 7.0	12.8 / 10.5 / 6.8	20.5 / 18.6 / 16.2
	Sound pressure level (Hi/Me/Lo)	dB(A)	39 / 31 / 22	43 / 34 / 27	43 / 36 / 28	43 / 40 / 36
	Exterior dimensions (HxWxD)	mm	290 x 870 x 230	290 x 870 x 230	290 x 870 x 230	339 x 1197 x 262
	Net weight	kg	10	10	10	15
Outdoor unit	Airflow rate	m ³ /min	26	31	34	55
	Sound pressure level	dB(A)	45	49	47	53
	Exterior dimensions (HxWxD)	mm	540 x 780 (+62) x 290	540 x 780 (+62) x 290	640 x 800 (+71) x 290	750 x 880 (+88) x 340
	Net weight	kg	33	33	40	58
Refrigerant type	type		R32	R32	R32	R32
	charge amount	kg (m)	0.75 (15m)	0.75 (15m)	1.05 (15m)	1.60 (15m)
Piping size (Liquid/Gas)		mm	φ6.35 / φ9.52	φ6.35 / φ9.52	φ6.35 / φ12.70	6.35 / φ15.88
Refrigerant line (one way) length		m	Max.20	Max.20	Max.25	Max.30
Vertical height differences		Outdoor is higher / lower	m	Max.10 / Max.10	Max.15 / Max.15	Max.20 / Max.20
Outdoor operating temperature range		°C	-15-46	-15-46	-15-46	-15-46

INVERTER SINGLE SPLIT STANDARD (COOLING) YW SERIES



Inverter



SRK10YW-W, SRK13YW-W, SRK15YW-W, SRK18YW-W



SRK10YW-W
SRK13YW-W



SRK15YW-W
SRK18YW-W

Inverter



SRK24YW-W



SRK24YW-W

REFRIGERANT PIPE LENGTH

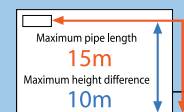

SRK10YW-W
SRK13YW-W

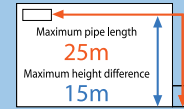

SRK15YW-W
SRK18YW-W

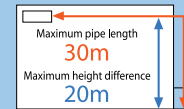

SRK24YW-W

FUNCTIONS

ENERGY SAVING



AIR FLOW



CLEAN OPERATION & FILTER



COMFORT & CONVENIENCE



OTHERS



SPECIFICATIONS

			YW SERIES				
			SRK10YW-W	SRK13YW-W	SRK15YW-W	SRK18YW-W	SRK24YW-W
			SRK10YW-W	SRK13YW-W	SRK15YW-W	SRK18YW-W	SRK24YW-W
Power source			1Phase, 220-240V, 50Hz	1Phase, 220-240V, 50Hz	1Phase, 220-240V, 50Hz	1Phase, 220-240V, 50Hz	1Phase, 220-240V, 50Hz
Capacity	Cooling	kW	2.5	3.2	4.5	5.0	6.9
		Btu/h	8,530	10,910	15,350	17,060	23,540
Power consumption	Cooling	kW	0.745	1.055	1.32	1.47	1.88
COP	Cooling	W/W	3.36	3.03	3.41	3.40	3.67
Inrush current / Max. current		A	3.7 / 7.5	5.1 / 7.5	6.0 / 12.5	6.7 / 12.5	8.8 / 12.5
Indoor unit	Airflow rate (Hi/Me/Lo)	m ³ /min	10.0 / 7.3 / 4.2	9.5 / 6.8 / 4.2	9.0 / 7.2 / 3.8	10.9 / 7.9 / 4.2	20.5 / 15.7 / 10.4
	Sound pressure level (Hi/Me/Lo)	dB(A)	43 / 34 / 24	44 / 34 / 25	42 / 36 / 23	48 / 39 / 24	41 / 33 / 23
	Exterior dimensions (HxWxD)	mm	267 x 783 x 210	267 x 783 x 210	267 x 783 x 210	267 x 783 x 210	339 x 1197 x 262
	Net weight	kg	7	7	7	7	15
Outdoor unit	Airflow rate	m ³ /min	23	22	35	35	41
	Sound pressure level	dB(A)	44	47	51	53	52
	Exterior dimensions (HxWxD)	mm	540 x 645(+57) x 275	540 x 645(+57) x 275	595 x 780(+62) x 290	595 x 780(+62) x 290	640 x 800(+71) x 290
	Net weight	kg	26	27	35	35	42
Refrigerant type	type		R32	R32	R32	R32	R32
	charge amount	kg (m)	0.55 (10m)	0.60 (10m)	1.10 (15m)	1.10 (15m)	1.25 (15m)
Piping size (Liquid/Gas)		mm	φ6.35 / φ9.52	φ6.35 / φ9.52	φ6.35 / φ12.70	φ6.35 / φ12.70	φ6.35 / φ12.70
Refrigerant line (one way) length		m	Max.15	Max.15	Max.25	Max.25	Max.30
Vertical height differences	Outdoor is higher / lower	m	Max.10 / Max.10	Max.10 / Max.10	Max.15 / Max.15	Max.15 / Max.15	Max.20 / Max.20
Outdoor operating temperature range		°C	-15~46	-15~46	-15~46	-15~46	-15~46

* Only SRK10YW-W, SRK13YW-W, SRK15YW-W, SRK18YW-W

INVERTER SINGLE SPLIT PREMIUM (COOLING) YL/YLV SERIES



Inverter



REFRIGERANT PIPE LENGTH

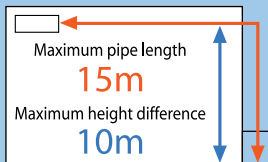

SRK10YL-S/YLV-S
SRK13YL-S/YLV-S

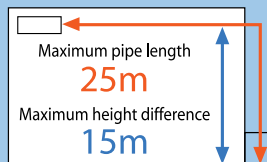

SRK18YL-S/YLV-S



SRC10YL-S/YLV-S
SRC13YL-S/YLV-S



SRC18YL-S/YLV-S

FUNCTIONS

ENERGY SAVING



AIR FLOW



CLEAN OPERATION & FILTER



COMFORT & CONVENIENCE



OTHERS



SPECIFICATIONS

			YL/YLV SERIES		
			SRK10YL-S/YLV-S	SRK13YL-S/YLV-S	SRK18YL-S/YLV-S
Indoor					
Outdoor			SRC10YL-S/YLV-S	SRC13YL-S/YLV-S	SRC18YL-S/YLV-S
Power source			1Phase, 220-240V, 50Hz		1Phase, 220-240V, 50Hz
Capacity	Cooling	kW	2.5	3.5	5.0
		Btu/h	8,530	11,940	17,060
Power consumption		Cooling kW	0.67	0.98	1.56
COP		Cooling W/W	3.73	3.57	3.21
Inrush current / Max. current		A	3.4	4.7	7.5
Indoor unit	Airflow rate (Hi/Me/Lo)	m ³ /min	8.0 / 6.2 / 4.5	10.0 / 6.8 / 4.6	12.0 / 7.6 / 4.7
	Sound pressure level (Hi/Me/Lo)	dB(A)	39 / 30 / 24	44 / 34 / 28	49 / 37 / 28
	Exterior dimensions (HxWxD)	mm	268 x 790 x 213	268 x 790 x 213	268 x 790 x 213
	Net weight	kg	8	8	9
Outdoor unit	Airflow rate	m ³ /min	30	28	38
	Sound pressure level	dB(A)	48	51	55
	Exterior dimensions (HxWxD)	mm	540 x 780(+62) x 290	540 x 780(+62) x 290	595 x 780(+62) x 290
	Net weight	kg	29	32	35
Refrigerant type	type		R410A		
	charge amount	kg (m)	0.70(15m)	0.95(15m)	1.30(15m)
Piping size (Liquid/Gas)		mm	φ6.35 / φ9.52	φ6.35 / φ9.52	φ6.35 / φ12.7
Refrigerant line (one way) length		m	Max.15		
Vertical height differences		Outdoor is higher / lower	m		Max.10 / Max.10
Outdoor operating temperature range		°C	21-43		

INVERTER SINGLE SPLIT STANDARD (COOLING) YN SERIES



Inverter



REFRIGERANT PIPE LENGTH

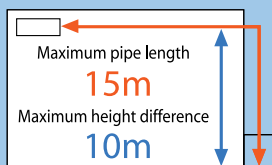

SRK10YN-S
SRK13YN-S

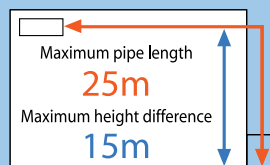

SRK18YN-S



SRC10YN-S
SRC13YN-S



SRC18YN-S

FUNCTIONS

ENERGY SAVING



AIR FLOW



CLEAN OPERATION & FILTER



COMFORT & CONVENIENCE



OTHERS



SPECIFICATIONS

			YN SERIES		
Indoor			SRK10YN-S	SRK13YN-S	SRK18YN-S
Outdoor			SRC10YN-S	SRC13YN-S	SRC18YN-S
Power source			1Phase, 220-240V, 50Hz		1Phase, 220-240V, 50Hz
Capacity	Cooling	kW	2.5	3.2	5.0
		Btu/h	8,530	10,910	17,060
Power consumption		Cooling kW	0.77	1.00	1.64
COP		Cooling W/W	3.25	3.20	3.05
Inrush current / Max. current		A	3.9 / 7.5	4.9 / 7.5	7.8 / 12.5
Indoor unit	Airflow rate (Hi/Me/Lo)	m ³ /min	10.1 / 7.3 / 4.2	9.5 / 6.8 / 4.2	10.1 / 7.2 / 3.8
	Sound pressure level (Hi/Me/Lo)	dB(A)	43 / 36 / 24	44 / 37 / 25	49 / 39 / 25
	Exterior dimensions (HxWxD)	mm	262 x 769 x 210	262 x 769 x 210	262 x 769 x 210
	Net weight	kg	7	7	7
Outdoor unit	Airflow rate (Hi/Me/Lo)	m ³ /min	26	25	35
	Sound pressure level (Hi/Me/Lo)	dB(A)	47	49	55
	Exterior dimensions (HxWxD)	mm	540 x 645(+57) x 275	540 x 645(+57) x 275	595 x 780(+62) x 290
	Net weight	kg	25	27	39
Refrigerant type	type		R410A		
	charge amount	kg (m)	0.65 (10m)	0.75 (15m)	1.20 (15m)
Piping size (Liquid/Gas)		mm	φ6.35 / φ9.52	φ6.35 / φ9.52	φ6.35 / φ12.7
Refrigerant line (one way) length		m	Max. 15	Max. 15	Max. 25
Vertical height differences		Outdoor is higher / lower	m	Max.10 / Max.10	Max.15 / Max.15
Outdoor operating temperature range		°C	21-43		

CONSTANT SPEED SINGLE SPLIT DELUXE (COOLING) CVS SERIES



SRK10CVS-W, SRK13CVS-W



REFRIGERANT PIPE LENGTH

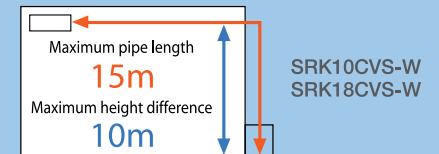

SRC10CVS-W

SRC13CVS-W

REFRIGERANT PIPE LENGTH

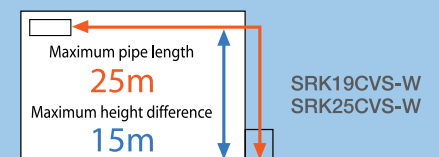

SRC19CVS-W

SRC25CVS-W

FUNCTIONS

ENERGY SAVING



AIR FLOW



CLEAN OPERATION & FILTER



COMFORT & CONVENIENCE



OTHERS

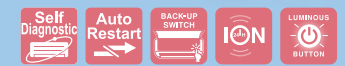

SPECIFICATIONS

			CVS SERIES			
			SRK10CVS-W	SRK13CVS-W	SRK19CVS-W	SRK25CVS-W
Indoor						
Outdoor			SRC10CVS-W	SRC13CVS-W	SRC19CVS-W	SRC25CVS-W
Power source			1Phase, 220-240V, 50Hz	1Phase, 220-240V, 50Hz	1Phase, 220-240V, 50Hz	1Phase, 220-240V, 50Hz
Capacity	Cooling	kW	2.7	3.6	5.4	7.4
		Btu/h	9,210	12,280	18,420	25,240
Power consumption	Cooling	kW	0.725	0.965	1.31	1.975
COP	Cooling	W/W	3.72	3.73	4.12	3.75
Inrush current		A	18.0	22.0	35.0	46.0
Indoor unit	Airflow rate (Hi)	m ³ /min	9.1	9.2	19.0	22.0
	Sound pressure level (Hi)	dB(A)	40	40	40	46
	Exterior dimensions (HxWxD)	mm	268 x 790 x 224	268 x 790 x 224	339 x 1197 x 262	339 x 1197 x 262
	Net weight	kg	9	9	16	16
Outdoor unit	Airflow rate	m ³ /min	32	32	37	60
	Sound pressure level	dB(A)	49	49	50	55
	Exterior dimensions (HxWxD)	mm	540 x 780(+62) x 290	540 x 780(+62) x 290	640 x 800(+71) x 290	750 x 880(+88) x 340
	Net weight	kg	29	31	44	57
Refrigerant type	type		R32	R32	R32	R32
	charge amount	kg (m)	0.67 (7.5m)	0.80 (7.5m)	1.00 (15m)	1.20 (15m)
Piping size (Liquid/Gas)		mm	φ6.35 / φ9.52	φ6.35 / φ12.70	φ6.35 / φ15.88	φ6.35 / φ15.88
Refrigerant line (one way) length		m	Max.15	Max.15	Max.25	Max.25
Vertical height differences	Outdoor is higher / lower	m	Max.10 / Max.10	Max.10 / Max.10	Max.15 / Max.15	Max.15 / Max.15
Outdoor operating temperature range		°C	15-43	15-43	15-43	15-43

CONSTANT SPEED SINGLE SPLIT DELUXE (COOLING) CRS SERIES



FUNCTIONS

ENERGY SAVING



AIR FLOW



CLEAN OPERATION & FILTER



COMFORT & CONVENIENCE



OTHERS



Refrigerant Pipe Length

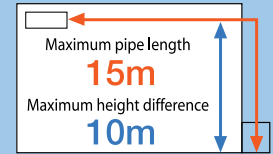

SPECIFICATIONS

			CRS SERIES	
			SRK10CRS-S	SRK13CRS-S
Indoor				
Outdoor			SRC10CRS-S	SRC13CRS-S
Power source			1Phase, 220-240V, 50Hz	1Phase, 220-240V, 50Hz
Capacity	Cooling	KW	2.7	3.6
		Btu/h	9,210	12,280
Power consumption	Cooling	KW	0.74	1
		COP	3.65	3.60
Inrush current		A	8.9	12.0
Indoor unit	Airflow rate (Hi)	m ³ /min	10.0	10.0
	Sound pressure level (Hi)	dB(A)	40	40
	Exterior dimensions (HxWxD)	mm	268 x 790 x 222	268 x 790 x 222
	Net weight	kg	9	9
Outdoor unit	Airflow rate	m ³ /min	26	35
	Sound pressure level	dB(A)	48	49
	Exterior dimensions (HxWxD)	mm	540 x 780(+62) x 290	540 x 780(+62) x 290
	Net weight	kg	28	35
Refrigerant type	type		R410A	R410A
	charge amount	kg (m)	0.58 (5m)	1.1 (5m)
Piping size (Liquid/Gas)		mm	φ6.35 / φ9.52	φ6.35 / φ12.70
Refrigerant line (one way) length		m	Max.15	Max.15
Vertical height differences	Outdoor is higher / lower	m	Max.5 / Max.5	Max.5 / Max.5
Outdoor operating temperature range		°c	15-43	15-43

SRK10CRS-S
SRK13CRS-S



SRK10CRS-S



SRK13CRS-S

CONSTANT SPEED SINGLE SPLIT DELUXE (COOLING) CSS SERIES



FUNCTIONS

ENERGY SAVING



AIR FLOW



CLEAN OPERATION & FILTER



COMFORT & CONVENIENCE



OTHERS



REFRIGERANT PIPE LENGTH

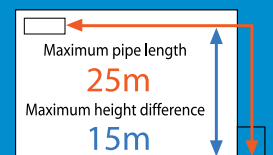

SPECIFICATIONS

			CSS SERIES	
			SRK19CSS-S	SRK25CSS-S
Indoor				
Outdoor			SRC19CSS-S	SRC25CSS-S
Power source			1Phase, 220-240V, 50Hz	1Phase, 220-240V, 50Hz
Capacity	Cooling	KW	5.4	7.4
		Btu/h	18,420	25,240
Power consumption	Cooling	KW	1.46	2.065
		COP	3.70	3.58
Inrush current		A	9.0	46.0
Indoor unit	Airflow rate (Hi)	m ³ /min	16.0	22.0
	Sound pressure level (Hi)	dB(A)	42	46
	Exterior dimensions (HxWxD)	mm	339 x 1,197 x 262	339 x 1,197 x 262
	Net weight	kg	16	16
Outdoor unit	Airflow rate	m ³ /min	38	60
	Sound pressure level	dB(A)	50	55
	Exterior dimensions (HxWxD)	mm	640 x 850(+65) x 290	750 x 880(+88) x 340
	Net weight	kg	44	57
Refrigerant type	type		R410A	R410A
	charge amount	kg (m)	1.10 (10m)	1.64 (7.5m)
Piping size (Liquid/Gas)		mm	φ6.35 / φ15.88	φ6.35 / φ15.88
Refrigerant line (one way) length		m	Max. 25	Max. 25
Vertical height differences	Outdoor is higher / lower	m	Max.15 / Max.15	Max.15 / Max.15
Outdoor operating temperature range		°c	15-43	15-43

SRK19CSS-S
SRK25CSS-S



SRK19CSS-S



SRK25CSS-S

CONSTANT SPEED SINGLE SPLIT STANDARD (COOLING) CR/CRR / CT/CTR SERIES



SRK09CRR-S
SRK12CR-S



SRK09CTR-S
SRK12CT-S



FUNCTIONS

ENERGY SAVING



AIR FLOW



COMFORT & CONVENIENCE



CLEAN OPERATION & FILTER



CT/CTR CR/CRR

OTHERS



REFRIGERANT PIPE LENGTH

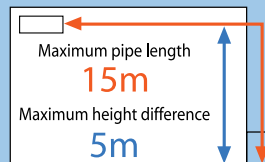

SRK09CRR-S
SRK12CR-S
SRK09CTR-S
SRK12CT-S



SRC09CRR-S/CTR-S



SRC12CR-S/CT-S

SPECIFICATIONS

			CRR/CTR/CR/CT SERIES			
			SRK09CRR-S	SRK09CTR-S	SRK12CR-S	SRK12CT-S
Indoor						
Outdoor			SRC09CRR-S	SRC09CTR-S	SRC12CR-S	SRC12CT-S
Power source			1Phase, 220-240V, 50Hz	1Phase, 220-240V, 50Hz	1Phase, 220-240V, 50Hz	1Phase, 220-240V, 50Hz
Capacity	Cooling	kW	2.64	2.64	3.45	3.45
		Btu/h	9,000	9,000	11,770	11,770
Power consumption		Cooling kW	0.868	0.868	1.12	1.12
COP		Cooling W/W	3.04	3.04	3.08	3.08
Inrush current		A	15.0	18.0	7.5	22.0
Indoor unit	Airflow rate (Hi)	m ³ /min	10.0	10.5	15.0	10.5
	Sound pressure level (Hi)	dB(A)	43	43	43	43
	Exterior dimensions (HxWxD)	mm	262 x 769 x 210	262 x 769 x 230	268 x 790 x 222	262 x 769 x 230
	Net weight	kg	7	7	7	7
Outdoor unit	Airflow rate	m ³ /min	23	23	38	32
	Sound pressure level	dB(A)	50	50	50	51
	Exterior dimensions (HxWxD)	mm	435 x 645(+50) x 275	435 x 645(+50) x 275	595 x 780(+62) x 290	595 x 780(+62) x 290
	Net weight	kg	24	24	31	31
Refrigerant type	type		R410A	R410A	R410A	R410A
	charge amount	kg (m)	0.54 (5m)	0.54 (5m)	0.78 (5m)	0.78 (5m)
Piping size (Liquid/Gas)		mm	φ6.35 / φ9.52	φ6.35 / φ9.52	φ6.35 / φ12.70	φ6.35 / φ12.70
Refrigerant line (one way) length		m	Max. 15	Max. 15	Max. 15	Max. 15
Vertical height differences		Outdoor is higher / lower	m	Max.5 / Max.5	Max.5 / Max.5	Max.5 / Max.5
Outdoor operating temperature range		°C	15~43	15~43	15~43	15~43

* Only SRK09CTR-S, SRK12CT-S

CONSTANT SPEED SINGLE SPLIT STANDARD (COOLING) CVV SERIES



SRK10CVV-W,
SRK13CVV-W

REFRIGERANT PIPE LENGTH

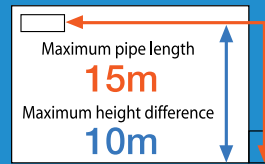

SRK10CVV-W
SRK13CVV-W

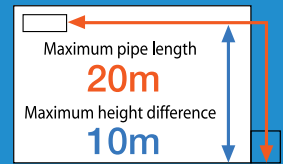

SRK15CVV-W



SRK15CVV-W



SRC10CVV-W



SRC13CVV-W
SRC15CVV-W
SRC18CVV-W

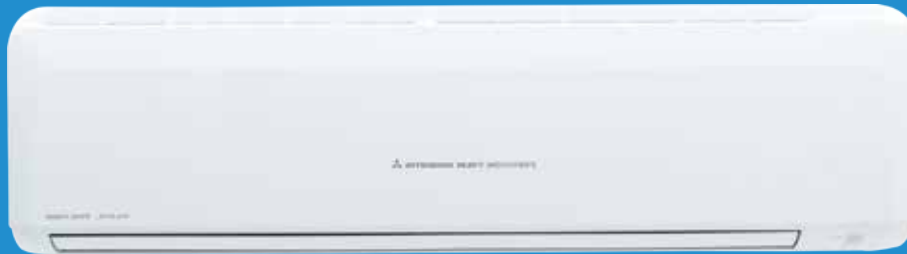

SRK18CVV-W, SRK24CVV-W

REFRIGERANT PIPE LENGTH

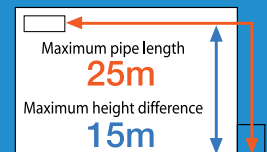

SRK18CVV-W
SRK24CVV-W

FUNCTIONS

ENERGY SAVING



AIR FLOW



CLEAN OPERATION & FILTER



COMFORT & CONVENIENCE



OTHERS



SRC24CVV-W

SPECIFICATIONS

			CVV SERIES					
			SRK10CVV-W	SRK13CVV-W	SRK15CVV-W	SRK18CVV-W	SRK24CVV-W	
			SRC10CVV-W	SRC13CVV-W	SRC15CVV-W	SRC18CVV-W	SRC24CVV-W	
Power source			1Phase, 220-240V, 50Hz	1Phase, 220-240V, 50Hz	1Phase, 220-240V, 50Hz	1Phase, 220-240V, 50Hz	1Phase, 220-240V, 50Hz	
Capacity	Cooling	kW	2.7	3.4	4.2	5.3	6.6	
		Btu/h	9,210	11,600	14,330	18,080	22,510	
Power consumption		Cooling kW	0.725	0.915	1.09	1.355	1.76	
COP		Cooling W/W	3.72	3.72	3.85	3.91	3.75	
Inrush current			A	17.0	23.0	21.4	25.0	37.0
Indoor unit	Airflow rate (Hi)	m ³ /min	8.5	9.2	10.1	17.4	19.3	
	Sound pressure level (Hi)	dB(A)	40	40	41	38	43	
	Exterior dimensions (HxWxD)	mm	262 x 769 x 230	262 x 769 x 230	290 x 870 x 230	339 x 1197 x 262	339 x 1197 x 262	
	Net weight	kg	7	7	9	16	16	
Outdoor unit	Airflow rate	m ³ /min	32	32	32	32	58	
	Sound pressure level	dB(A)	49	49	48	50	54	
	Exterior dimensions (HxWxD)	mm	540 x 780(+62) x 290	595 x 780(+62) x 290	595 x 780(+62) x 290	595 x 780(+62) x 290	750 x 880(+88) x 340	
	Net weight	kg	29	32	32	36	51	
Refrigerant type	type		R32	R32	R32	R32	R32	
	charge amount	kg (m)	0.45 (7.5m)	0.67 (7.5m)	0.82 (7.5m)	1.05 (7.5m)	0.87 (7.5m)	
Piping size (Liquid/Gas)		mm	φ6.35 / φ9.52	φ6.35 / φ12.7	φ6.35 / φ12.7	φ6.35 / φ15.88	φ6.35 / φ15.88	
Refrigerant line (one way) length		m	Max. 15	Max. 15	Max. 20	Max. 25	Max. 25	
Vertical height differences		Outdoor is higher / lower	m	Max.10 / Max.10	Max.10 / Max.10	Max.10 / Max.10	Max.15 / Max.15	Max.15 / Max.15
Outdoor operating temperature range		°C	15-43	15-43	15-43	15-43	15-43	

* Only SRK10CVV-W, SRK13CVV-W

CONSTANT SPEED SINGLE SPLIT STANDARD (COOLING) CS SERIES



SRK18CS-S



REFRIGERANT PIPE LENGTH

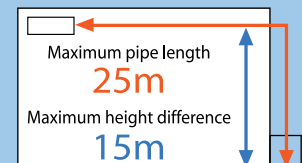

SRK18CS-S
SRK24CS-S



SRK24CS-S



SRC18CS-S
SRC24CS-S

FUNCTIONS

ENERGY SAVING



AIR FLOW



CLEAN OPERATION & FILTER



COMFORT & CONVENIENCE



OTHERS

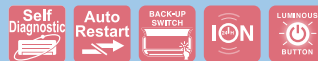

*24-HOUR ION for SRK24CS-S only

SPECIFICATIONS

			CS SERIES	
Indoor			SRK18CS-S	SRK24CS-S
Outdoor			SRC18CS-S	SRC24CS-S
Power source			1Phase, 220-240V, 50Hz	
Capacity	Cooling	kW	5.10	7.20
		Btu/h	17,400	24,560
Power consumption	Cooling	kW	1.6	2.2
COP	Cooling	W/W	3.19	3.27
Inrush current			A	46.0
Indoor unit	Airflow rate (Hi)	m ³ /min	12.8	22.0
	Sound pressure level (Hi)	dB(A)	47	46
	Exterior dimensions (HxWxD)	mm	309 x 890 x 251	339 x 1197 x 262
	Net weight	kg	12	16
Outdoor unit	Airflow rate	m ³ /min	38	38
	Sound pressure level	dB(A)	50	54
	Exterior dimensions (HxWxD)	mm	640 x 850(+65) x 290	640 x 850(+65) x 290
	Net weight	kg	39	46
Refrigerant type	type		R410A	
	charge amount	kg (m)	0.90 (5m)	1.27 (7.5m)
Piping size (Liquid/Gas)		mm	φ6.35 / φ15.88	
Refrigerant line (one way) length		m	Max.25	
Vertical height differences	Outdoor is higher / lower	m	Max.15 / Max.15	
Outdoor operating temperature range		°C	21~43	

INVERTER MULTI-SPLIT SYSTEM



THE MULTI-SPLIT SYSTEM allows a single outdoor unit to service a range of configurations of up to six indoor units, form a lineup of 8 units ranging from 6.0kW to 19.5kW.

ENERGY SAVING

All models can achieve very high seasonal efficiency thanks to the application of inverter technology which makes it possible to vary the power output according to demand for cooling or heating. This makes it possible to reach the set temperature quickly and to keep it stable over time saving about 30% in consumption compared to traditional fixed speed air conditioners.

SEER in Cooling



* The above values are based on indoor unit combination with SRK-ZSX only.

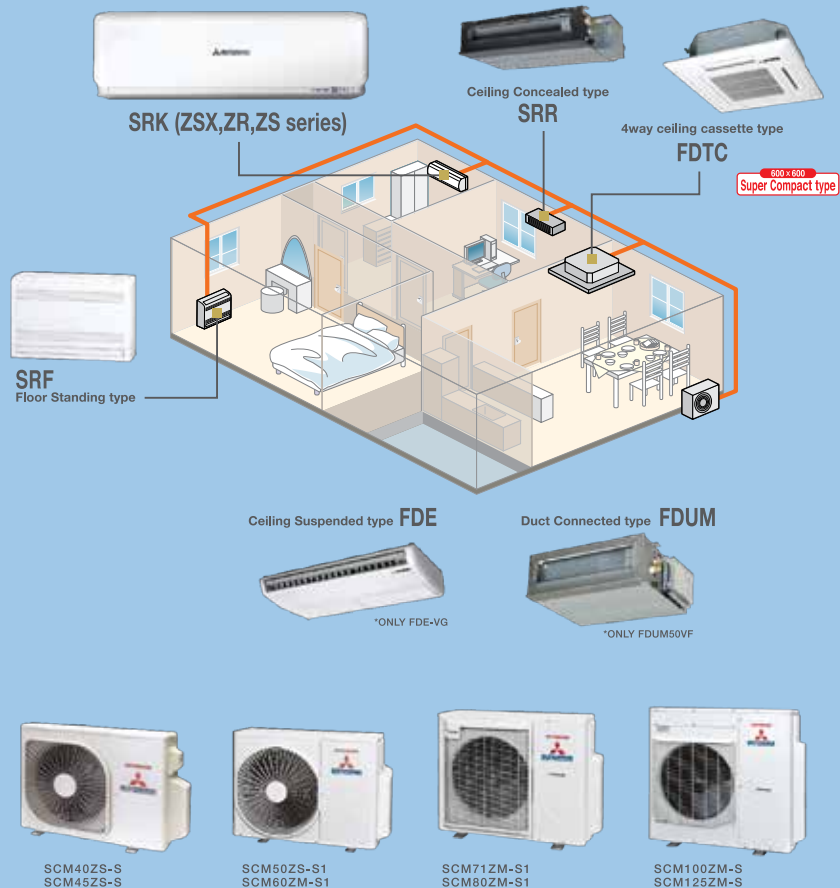

LONG PIPING LENGTH

The maximum piping length of the refrigerant pipes for the outdoor units, and the maximum height difference for the outdoor units are as shown below.

		SCM40/45ZS-S	SCM50ZS-S/SCM60ZM-S	SCM71/80ZM-S	SCM100/125ZM-S
Length for one indoor unit		Under 25 m	Under 25 m	Under 25 m	Under 25 m
Total length for all rooms		Under 30 m	Under 40 m	Under 70 m	Under 90 m
Height Difference	Lower installation spot of the indoor unit (a)	Under 15 m	Under 15 m	Under 20 m	Under 20 m
	Upper installation spot of the indoor unit (b)	Under 15 m	Under 15 m	Under 20 m	Under 20 m
	Maximum height difference of the indoor units (c)	Under 25 m	Under 25 m	Under 25 m	Under 25 m
Length of precharged refrigerant pipe		30 m	40 m	40 m	50 m

OUTDOOR UNIT SPECIFICATIONS

ITEM	MODEL	FOR TWO ROOMS		FOR THREE ROOMS		FOR FOUR ROOMS		FOR FIVE / SIX ROOMS	
		SCM40ZS-S	SCM45ZS-S	SCM50ZS-S1	SCM60ZM-S1	SCM71ZM-S1	SCM80ZM-S1	SCM100ZM-S	SCM125ZM-S
Power source		1 phase, 220 - 240v, 50 Hz		1 phase, 220 - 240v, 50 Hz		1 phase, 220 - 240v, 50 Hz		1 phase, 220 - 240v, 50 Hz	
Nominal cooling capacity (Min-Max)	kW	4.0(1.5-5.9)	4.5(1.5-6.4)	5.0(1.8-7.1)	6.0(1.8-7.5)	7.1(1.8-8.8)	8.0(1.8-9.2)	10.0(1.8-12.0)	12.5(1.8-14.0)
Nominal heating capacity (Min-Max)	kW	4.5(1.3-6.3)	5.3(1.3-6.5)	6.0(1.4-7.5)	6.8(1.5-7.8)	8.6(1.5-9.4)	9.3(1.5-9.8)	12.0(1.5-13.5)	13.5(1.5-14.0)
Power Consumption	Cooling	0.84(0.59-2.13)	1.04(0.59-2.30)	1.05(0.60-2.15)	1.43(0.50-2.39)	1.59(0.48-2.75)	1.95(0.48-2.83)	2.86(0.65-4.03)	3.90(0.65-4.80)
	Heating	0.90(0.54-1.70)	1.15(0.54-1.92)	1.21(0.55-2.58)	1.45(0.60-3.00)	2.00(0.60-3.35)	2.26(0.60-3.43)	2.93(0.70-3.40)	3.25(0.70-3.42)
EER	Cooling	4.76	4.33	4.76	4.20	4.49	4.10	3.50	3.21
	Heating	5.00	4.61	4.96	4.69	4.30	4.12	4.10	4.15
COP	Cooling	5.00	4.61	4.96	4.69	4.30	4.12	4.10	4.15
	Heating	5.00	4.61	4.96	4.69	4.30	4.12	4.10	4.15
Max. running current	A	14	14	14	17	20	20	29	29
	W	14	14	14	17	20	20	29	29
Sound power level	Cooling	62	62	61	63	63	66	68	69
	Heating	64	64	63	65	66	6	71	72
Sound pressure level	Cooling	48	49	48	50	50	54	56	57
	Heating	50	50	50	52	54	54	59	60
Air Flow	Cooling	32.5	32.5	41.0	42.0	50.0	56.0	75.0	75.0
	Heating	32.5	32.5	41.0	42.0	56.0	56.0	75.0	82.0
Exterior dimension (H x W x D)	mm	595 x 780(+90) x 290		640 x 850(+65) x 290		750 x 880(+73) x 340		945 x 970(+73) x 370	
Net weight	kg	42	42	49	49	62	62	92	92
	kg	42	42	49	49	62	62	92	92
Refrigerant type	type	R410		R410		R410		R410	
	charge amount	kg	1.90	2.50	2.50	3.15	3.15	6.00	6.00
Piping size	Liquid	mm	φ6.35 x 2	φ6.35 x 3	φ6.35 x 3	φ6.35 x 4	φ6.35 x 5	φ6.35 x 6	φ6.35 x 6
	Gas	mm	φ9.52 x 2	φ9.52 x 3	φ9.52 x 3	φ9.52 x 4	φ9.52 x 5	φ9.52 x 6	φ9.52 x 6
Outdoor operating temperature range	Cooling	°C	-15-43	-15-43	-15-43	-15-43	-15-43	-15-43	-15-43
	Heating	°C	-15-24	-15-24	-15-24	-15-24	-15-24	-15-24	-15-24
Number of Connectable Indoor units		2	2	Min.2-Max.3	Min.2-Max.3	Min.2-Max.4	Min.2-Max.4	Min.4-Max.5	Min.2-Max.6
Total indoor units capacity	kW	6.0	7.0	8.5	11.0	12.5	13.5	16.0	19.5

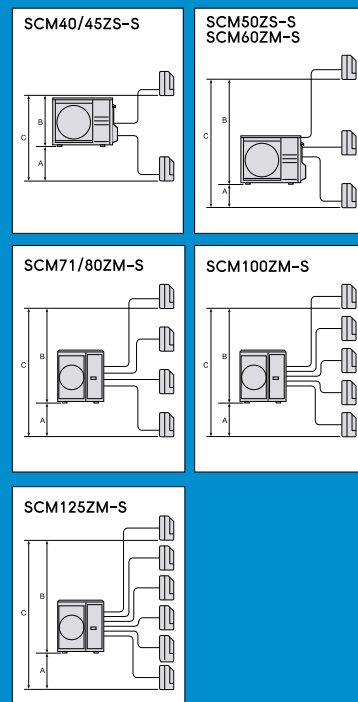

* The data are measured under the following conditions (ISO-T1). Cooling: Indoor temp. of 27°CDB, 19°CWB, and outdoor temp. of 35°CDB. Heating: Indoor temp. of 20°CDB, and outdoor temp. of 7°CDB, 6°CWB.
 * Sound level indicates the value in an anechoic chamber. During operation these values are somewhat higher due to ambient conditions.
 * In case of SRK71ZR-S/S, SRK71ZR-S, 2 indoor units can be connectable. In case of the combination with SRK71ZR-S & FDE50VG, only 3 indoor units can be connectable. The total connecting capacity of indoor units should be between 100 - 160.

SRK-ZSX

Inverter

WALL MOUNTED TYPE



Black & White (-WB)



Titanium (-WT)



FUNCTIONS

ENERGY SAVING



AIR FLOW

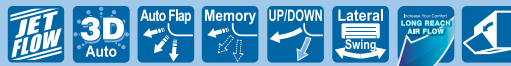

CLEAN OPERATION & FILTER



COMFORT & CONVENIENCE



OTHERS



SPECIFICATIONS

ITEM	M ODEL	SRK20ZSX-W	SRK25ZSX-W	SRK35ZSX-W	SRK50ZSX-W	SRK60ZSX-W
Capacity	Cooling	kW	2.0	2.5	3.5	5.0
	Heating	kW	3.0	3.4	4.5	5.8
Airflow rate (Hi/Me/Lo)	Cooling	m ³ /min	11.3 / 9.1 / 6.0	12.2 / 10.0 / 6.7	13.1 / 10.8 / 7.3	14.3 / 12.4 / 7.8
	Heating	m ³ /min	12.2 / 10.3 / 7.2	12.8 / 11.0 / 7.8	13.9 / 11.8 / 8.6	17.3 / 14.3 / 9.8
"Sound pressure level (Hi/Me/Lo)"	Cooling	dB(A)	38 / 31 / 24	39 / 33 / 25	43 / 35 / 26	44 / 39 / 31
	Heating	dB(A)	38 / 33 / 25	40 / 34 / 27	42 / 35 / 28	46 / 41 / 33
Exterior dimensions (HxWxD)	mm	305 x 920 x 220	305 x 920 x 220	305 x 920 x 220	305 x 920 x 220	305 x 920 x 220
Net weight	kg	13	13	13	13	13
Refrigerant piping size	Liquid/Gas	mm	φ6.35 / φ9.52	φ6.35 / φ9.52	φ6.35 / φ9.52	φ6.35 / φ12.70
Clean Filter		Allergen Clear Filter x 1, Photocatalytic Washable Deodorizing Filter x 1				

SRK-ZS

Inverter

WALL MOUNTED TYPE



Black & White (-WB)



Titanium (-WT)



FUNCTIONS

ENERGY SAVING



AIR FLOW



CLEAN OPERATION & FILTER



COMFORT & CONVENIENCE



OTHERS



SPECIFICATIONS

ITEM	M ODEL	SRK20ZS-W,-WB,-WT	SRK25ZS-W,-WB,-WT	SRK35ZS-W,-WB,-WT	SRK50ZS-W,-WB,-WT
Capacity	Cooling	kW	2.0	2.5	3.5
	Heating	kW	3.0	3.4	4.5
Airflow rate (Hi/Me/Lo)	Cooling	m ³ /min	9.3 / 7.0 / 5.9	9.9 / 8.0 / 5.9	11.3 / 8.7 / 7.0
	Heating	m ³ /min	10.0 / 8.5 / 6.5	11.3 / 8.7 / 6.7	12.3 / 11.0 / 7.0
"Sound pressure level (Hi/Me/Lo)"	Cooling	dB(A)	34 / 25 / 22	36 / 28 / 23	40 / 30 / 26
	Heating	dB(A)	36 / 29 / 23	39 / 30 / 24	41 / 36 / 25
Exterior dimensions (HxWxD)	mm	290 x 870 x 230	290 x 870 x 230	290 x 870 x 230	290 x 870 x 230
Net weight	kg	9.5	9.5	9.5	10.0
Refrigerant piping size	Liquid/Gas	mm	φ6.35 / φ9.52	φ6.35 / φ9.52	φ6.35 / φ12.70
Clean Filter		Allergen Clear Filter x 1, Photocatalytic Washable Deodorizing Filter x 1			

SRK-ZR

Inverter

WALL MOUNTED TYPE



FUNCTIONS

ENERGY SAVING



AIR FLOW



CLEAN OPERATION & FILTER



COMFORT & CONVENIENCE



OTHERS



SPECIFICATIONS

ITEM	M ODEL		SRK71ZR-W
Capacity	Cooling	kW	7.1
	Heating	kW	8.0
Airflow rate (Hi/Me/Lo)	Cooling	m3/min	20.5 / 18.6 / 16.2
	Heating		25.5 / 19.8 / 17.3
"Sound pressure level (Hi/Me/Lo)"	Cooling	dB(A)	44 / 41 / 37
	Heating	dB(A)	46 / 39 / 35
Exterior dimensions (HxWxD)		mm	339 x 1,197 x 262
Net weight		kg	15.5
Refrigerant piping size	Liquid/Gas	mm	φ6.35 / φ15.88
Clean Filter			Allergen Clear Filter x 1, Photocatalytic Washable Deodorizing Filter x 1

The data are measured under the following conditions (ISO-T1). Cooling: Indoor temp. of 27°CDB, 19°CWB, and outdoor temp. of 35°CDB. Heating: Indoor temp. of 20°CDB, and outdoor temp. of 7°CDB, 6°CWB.

SRF-ZMX

Inverter

FLOOR STANDING TYPE



FUNCTIONS

ENERGY SAVING



AIR FLOW



COMFORT & CONVENIENCE



CLEAN OPERATION & FILTER



OTHERS



WIRED REMOTE CONTROL (OPTION)



SPECIFICATIONS

ITEM	M ODEL		SRF25ZMX-S	SRF35ZMX-S	SRF50ZMX-S
Capacity	Cooling	kW	2.5	3.5	5.0
	Heating	kW	3.4	4.5	5.8
Airflow rate (Hi/Me/Lo)	Cooling	m ³ /min	9.0 / 7.6 / 6.7	9.2 / 7.8 / 7.3	11.5 / 9.6 / 7.4
	Heating		10.5 / 8.2 / 7.7	10.7 / 8.3 / 8.1	12.0 / 10.0 / 9.4
"Sound pressure level (Hi/Me/Lo)"	Cooling	dB(A)	40 / 32 / 29	41 / 34 / 32	46 / 42 / 35
	Heating	dB(A)	40 / 35 / 33	41 / 36 / 35	47 / 41 / 39
Exterior dimensions (HxWxD)		mm	600 x 860 x 238	600 x 860 x 238	600 x 860 x 238
Net weight		kg	18	19	19
Refrigerant piping size	Liquid/Gas	mm	φ6.35 / φ9.52	φ6.35 / φ9.52	φ6.35 / φ12.7
Clean Filter			Allergen Clear Filter x 1, Photocatalytic Washable Deodorizing Filter x 1		

SRR-ZM

CEILING CONCEALED TYPE

Inverter



FUNCTIONS

ENERGY SAVING



CLEAN OPERATION & FILTER



WIRELESS REMOTE CONTROL (OPTION)



WIRED REMOTE CONTROL (OPTION)



RC-EX3A

RC-E5

COMFORT & CONVENIENCE



OTHERS



SPECIFICATIONS

ITEM	M ODEL		SRR25ZM-S	SRR35ZM-S	SRR50ZM-S	SRR60ZM-S
Capacity	Cooling	kW	2.5	3.5	5.0	6.0
	Heating	kW	3.4	4.5	5.8	6.8
Airflow rate (Hi/Me/Lo)	Cooling	m ³ /min	9.5 / 8.0 / 6.5	10.0 / 8.5 / 7.0	13.5 / 11.0 / 10.0	14.5 / 11.5 / 10.5
	Heating		10.0 / 9.0 / 8.0	10.5 / 9.5 / 8.5	14.0 / 12.5 / 11.0	15.0 / 13.0 / 11.5
"Sound pressure level (Hi/Me/Lo)"	Cooling	dB(A)	37 / 33 / 30	38 / 34 / 31	41 / 37 / 34	44 / 38 / 35
	Heating	dB(A)	40 / 37 / 34	42 / 38 / 35	43 / 39 / 37	45 / 41 / 38
Exterior dimensions (HxWxD)		mm	200 x 750 x500	200 x 750 x500	200 x 950 x500	200 x 950 x500
Net weight		kg	20.5	20.5	24	24
Refrigerant piping size	Liquid/Gas	mm	φ6.35 / φ9.52	φ6.35 / φ9.52	φ6.35 / φ12.7	φ6.35 / φ12.7

The data are measured under the following conditions (ISO-T1). Cooling: Indoor temp. of 27°CDB, 19°CWB, and outdoor temp. of 35°CDB. Heating: Indoor temp. of 20°CDB, and outdoor temp. of 7°CDB, 6°CWB.

※ Indicates the value in an anechoic chamber. During operation these values are somewhat higher due to ambient conditions.

FDUM-VF

DUCT CONNECTED-LOW/MIDDLE STATIC PRESSURE

Inverter



FUNCTIONS

ENERGY SAVING



COMFORT & CONVENIENCE



OTHERS



FILTER KIT UM-FL1EF (OPTION)

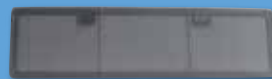

WIRED REMOTE CONTROL (OPTION)



RC-EX3A

RC-E5

RCH-E3

WIRELESS REMOTE CONTROL (OPTION)



RCN-KIT3-E

SPECIFICATIONS

ITEM	M ODEL		FDUM50VF
Capacity	Cooling	kW	5.0
	Heating	kW	5.8
Airflow rate (Hi/Me/Lo)	Cooling	m ³ /min	10.0 / 9.0 / 8.0
	Heating		10.0 / 9.0 / 8.0
"Sound pressure level (Hi/Me/Lo)"	Cooling	dB(A)	32 / 29 / 26
	Heating	dB(A)	32 / 29 / 26
Exterior dimensions (HxWxD)		mm	280 x 750 x 635
Net weight		kg	29
Refrigerant piping size	Liquid/Gas	mm	φ6.35 / φ12.7
Clean Filter			Filter KIT : UM-FL1EF(option)

The data are measured under the following conditions (ISO-T1). Cooling: Indoor temp. of 27°CDB, 19°CWB, and outdoor temp. of 35°CDB. Heating: Indoor temp. of 20°CDB, and outdoor temp. of 7°CDB, 6°CWB.

※ Indicates the value in an anechoic chamber. During operation these values are somewhat higher due to ambient conditions.

※ Powerful-Hi can be selected. Sound pressure level dB(A): Cooling: 37 Heating: 37, Air flow: 13m³/min

FDTC-VF

4WAY CEILING CASSETTE TYPE

Inverter

WIRED REMOTE CONTROL (OPTION)



RC-EX3A RC-E5 RCH-E3

WIRELESS REMOTE CONTROL (OPTION)



RCN-TC-24W-E2



FUNCTIONS

ENERGY SAVING



AIR FLOW



COMFORT & CONVENIENCE



OTHERS



SPECIFICATIONS

ITEM		M ODEL	FDTC25VF	FDTC35VF	FDTC50VF	FDTC60VF
Capacity	Cooling	kW	2.5	3.5	5.0	6.0
	Heating	kW	3.4	4.5	5.8	6.8
Airflow rate (Hi/Me/Lo)	Cooling	m ³ /min	9.0 / 8.0 / 6.5	9.5 / 9.0 / 7.0	11.5 / 9.0 / 7.0	13.5 / 10.0 / 7.0
	Heating		9.5 / 8.5 / 7.0	10.0 / 9.0 / 8.0	11.5 / 9.0 / 8.0	13.5 / 10.0 / 8.0
"Sound pressure level (Hi/Me/Lo)"	Cooling	dB(A)	36 / 32 / 29	40 / 36 / 30	42 / 36 / 30	46 / 39 / 30
	Heating	dB(A)	38 / 33 / 29	42 / 35 / 32	42 / 36 / 32	46 / 39 / 32
Exterior dimensions (HxWxD)		mm	248 x 570 x570	248 x 570 x570	248 x 570 x570	248 x 570 x570
Net weight		kg	15	15	15	15
Refrigerant piping size	Liquid/Gas	mm	φ6.35 / φ9.52	φ6.35 / φ9.52	φ6.35 / φ12.7	φ6.35 / φ12.7

FDE-VG

CEILING SUSPENDED

Inverter

FUNCTIONS

ENERGY SAVING



AIR FLOW



COMFORT & CONVENIENCE



OTHERS



WIRED REMOTE CONTROL (OPTION)



RC-EX3A RC-E5 RCH-E3

WIRELESS REMOTE CONTROL (OPTION)



RCN-E-E2



SPECIFICATIONS

ITEM		M ODEL	FDE50VG
Capacity	Cooling	kW	5.0
	Heating	kW	5.8
Airflow rate (Hi/Me/Lo)	Cooling	m ³ /min	10.0 / 9.0 / 7.0
	Heating		10.0 / 9.0 / 7.0
"Sound pressure level (Hi/Me/Lo)"	Cooling	dB(A)	38 / 36 / 31
	Heating	dB(A)	38 / 36 / 31
Exterior dimensions (HxWxD)		mm	210 x 1,070 x 690
Net weight		kg	28
Refrigerant piping size	Liquid/Gas	mm	φ6.35 / φ12.7
Clean Filter			Pocket Plastic Net x 2(Washable)

The data are measured under the following conditions (ISO-T1). Cooling: Indoor temp. of 27°CDB, 19°CWB, and outdoor temp. of 35°CDB. Heating: Indoor temp. of 20°CDB, and outdoor temp. of 7°CDB, 6°CWB.

* Indicates the value in an anechoic chamber. During operation these values are somewhat higher due to ambient conditions.

※ Powerful-Hi can be selected. Sound pressure level dB(A): Cooling: 46 Heating: 46, Air flow: 13m³/min

Before starting use

Heating performance

The heating performance values (kW) described in the catalogue are the values obtained by operating at an outdoor temperature of 7 C and indoor temperature of 20 C as set forth in the ISO Standards. As the heating performance decreases the outdoor temperature drops, if the outdoor temperature is too low and the heating performance is insufficient, use other heating appliances as well.

Indication of sound values

The sound values are the values (A scale) measured in a chamber such as an anechoic chamber following the ISO Standards. In the actual installation state, the value is normally larger than the values given in the catalog due to the effect of surrounding noise and echo. Take this into consideration when installing.

Use in oil atmosphere

Avoid installing this unit in an atmosphere where oil scatters or builds up, such as in a kitchen or machine factory.

If the oil adheres to the heat exchanger, the heat exchanging performance will drop, mist may be generated, and the synthetic resin parts may deform and break.

Use in acidic or alkaline atmosphere

If this unit is used in acidic atmosphere such as hot spring areas having high level of sulfuric gases or in alkaline atmosphere including ammonia or calcium chloride, places where the exhaust of the heat exchanger is sucked in, or at coastal areas where the unit is subject to salt breezes, the outer plate or heat exchanger, etc., will corrode. Please ask a dealer or specialist when you use an air conditioner in places differing from a general atmosphere.

Use in places with high ceilings

If the ceiling is high, install a circulator to improve the heat and air flow distribution when heating.

Refrigerant leakage

The refrigerant (R32, R410A) used for Air conditioner is non-toxic and inflammable in its original state. However, in consideration of a state where the refrigerant leaks into the room, measures against refrigerant leaks must be taken in small rooms where the tolerable level could be exceeded. Take measures by installing ventilation devices, etc.

Use in snowy areas

Take the following measures when installing the outdoor unit in snowy areas.

• Snow prevention

Install a snow-prevention hood so that the snow does not obstruct the air intake port or enter and freeze in the outdoor unit.

• Snow piling

In areas with heavy snow fall, the piled snow could block the air intake port. In this case, a frame that is 50cm or higher than the estimated snow fall must be installed underneath the outdoor unit.

Automatic defrosting device

If the temperature is low, and the humidity is high, frost will stick to the heat exchanger of the outdoor unit. If use is continued, the heating performance will drop.

The "Automatic defrosting device" will function to remove this frost.

After heating for approx. three to ten minutes, it will stop, and the frost will be removed. After defrosting, hot air will be blown again.

Servicing the air-conditioner

After the air-conditioner is used for several seasons, dirt will build up in the air-conditioner causing the performance to drop. In addition to regular servicing, we recommend the maintenance contract (charged for) by a specialist.

Safety Precautions

Air-conditioner usage target

The air-conditioner described in this catalog is a dedicated cooling/heating device for human use.

Do not use it for special applications such as the storage of food items, animals or plants, precision devices or valuable art, etc.

This could cause the quality of the items to drop, etc.

Do not use this for cooling vehicles or ships. Water leakage or current leaks could occur.

Before use

Always read the "User's Manual" thoroughly before starting use.

Installation

Always commission the installation to a dealer or specialist. Improper installation will lead to water leakage, electric shocks and fires.

Make sure that the outdoor unit is stable in installation. Fix the unit to stable base.

Usage place

Do not install in places where combustible gas could leak or where there are sparks.

Installation in a place where combustible gas could be generated, flow or accumulate, or places containing carbon fibers could lead to fires.

Mitsubishi Heavy Industries Thermal Systems, Ltd.

Japan Head Office : 16-5 2-Chome Kounan Minato-ku Tokyo 108-8215, Japan www.mhi-mth.co.jp

Mitsubishi Heavy Industries-Mahajak Air Conditioners Co., Ltd.

220 Soi Chalongsong 31, Lamplatiev, Lad Krabang, Bangkok 10520, Thailand www.mhi-air.maco.co.th

ISO9001

Our Air Conditioning & Refrigeration Systems Headquarters is an ISO9001 approved factory for residential air conditioners and commercial-use air conditioners (including heat pumps).



Mitsubishi Heavy Industries Thermal Systems, Ltd.
Certificate No: 001
Certificate Number: JQA-0709
Date of certification: December 16, 1994



MITSUBISHI HEAVY INDUSTRIES-MAHAJAK AIR CONDITIONERS CO., LTD.
Certificate No: 002
Certificate Number: 04100 1998 0813
Date of Registration: October 1998

ISO14001

Our Air Conditioning & Refrigeration Systems Headquarters has been assessed and found to comply with the requirements of ISO14001.



Mitsubishi Heavy Industries Thermal Systems, Ltd.
Certificate No: 14001
Certificate Number: YMA000636
Date of certification: December 27, 2017



MITSUBISHI HEAVY INDUSTRIES-MAHAJAK AIR CONDITIONERS CO., LTD.
Certificate No: 14001
Certificate Number: 04100 1998 0813 E5
Date of Registration: December 2005

Because of our policy of continuous improvement, we reserve right to make changes in all specifications without notice.

CATALOGUE NO. MACO 19-ASIA (REV.01)