



KXZ Hi-COP series

8~36HP(22.4kW~100.0kW)

Model No.	Nominal Cooling Capacity
FDC224KXZE1	22.4kW
FDC280KXZE1	28.0kW
FDC335KXZE1	33.5kW



• This series can connect indoor unit capacity up to 160~200%.

kW	capacity connection
22.4~45.0	200%
50.0~100.0	160%

- High efficiency with COP (in cooling) up to 4.5.
- These units employ DC inverter multiport compressors with concentrated winding motor.
- Industry leading total piping length up to 1000m and a maximum pipe run of 160m.

Model No.	Nominal Cooling Capacity
FDC450KXZE1 (FDC224+FDC224)	45.0kW
FDC500KXZE1 (FDC224+FDC280)	50.0kW
FDC560KXZE1 (FDC280+FDC280)	56.0kW
FDC615KXZE1 (FDC280+FDC335)	61.5kW
FDC670KXZE1 (FDC335+FDC335)	67.0kW
FDC735KXZE1 (FDC224+FDC224+FDC280)	73.5kW
FDC800KXZE1 (FDC224+FDC280+FDC280)	80.0kW
FDC850KXZE1 (FDC280+FDC280+FDC280)	85.0kW
FDC900KXZE1 (FDC280+FDC280+FDC335)	90.0kW
FDC950KXZE1 (FDC280+FDC335+FDC335)	95.0kW
FDC1000KXZE1 (FDC335+FDC335+FDC335)	100.0kW



FDC224KXZE1



FDC280KXZE1
FDC335KXZE1

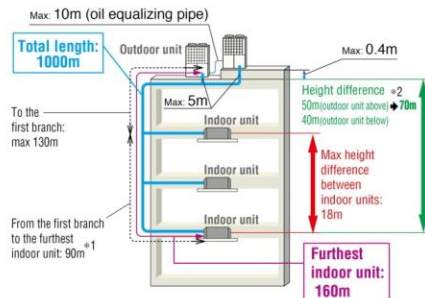

- *1 The difference between the longest and the shortest indoor unit piping from the first branch must be within 40m. (MAX85m)
- *2 In case of height difference up to 70m, please contact your dealer. Height difference up to 100m is possible with High Head series. Please refer to page56.

Range of operation

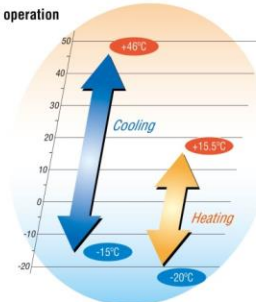

Specifications

Item	Model	FDC224KXZE1	FDC280KXZE1	FDC335KXZE1
Nominal horse power		8HP	10HP	12HP
Power source		3Phase 380-415V, 50Hz		
Starting current	A	5		
Max current	A	21.2	32	
Nominal capacity	Cooling	22.4	28.0	33.5
	Heating	25.0	31.5	37.5
Electrical characteristics	Power consumption	4.98	6.95	8.68
	Cooling Heating	5.56	6.83	8.39
Exterior dimensions	H x W x D	1690x1350x720		2048x1350x720
Net weight	kg	280	325	
Sound pressure level	Cooling / Heating	56/57		62/57
Refrigerant	Type / GWP	R410A / 2088		
	Charge	kg/CO ₂ Eq	11.0 / 22.968	11.5 / 24.012
Refrigerant piping size	Liquid line	ø9.52(3/8")		ø12.7(1/2")
	Gas line	ø19.05(3/4")	ø22.22(7/8")	ø25.4(1") [ø22.22(7/8")]
Capacity connection	%	200		
Number of connectable indoor units		29	37	44

Item	Model	FDC450KXZE1	FDC500KXZE1	FDC560KXZE1	FDC615KXZE1	FDC670KXZE1
Combination (FDC)		224KXZE1	224KXZE1	280KXZE1	280KXZE1	335KXZE1
		224KXZE1	280KXZE1	280KXZE1	335KXZE1	335KXZE1
Nominal horse power		16HP	18HP	20HP	22HP	24HP
Power source		3Phase 380-415V, 50Hz				
Starting current	A	10				
Max current	A	42.4	53.2	64		
Nominal capacity	Cooling	45.0	50.0	56.0	61.5	67.0
	Heating	50.0	56.0	63.0	69.0	75.0
Electrical characteristics	Power consumption	10.0	11.8	13.9	15.6	17.4
	Cooling Heating	11.1	12.3	13.7	15.2	16.8
Exterior dimensions	H x W x D	1690x2700x720		2048x2700x720		
Net weight	kg	560	605	650	650	650
Refrigerant charge	R410A	11.0x2	11.0+11.5	11.5x2		
Refrigerant piping size	Liquid line	ø12.7(1/2")				
	Gas line	ø28.58(1 1/8")				
	Oil equalization	ø9.52(3/8")				
Capacity connection	%	200	160			
Number of connectable indoor units		60	53	59	65	71

Item	Model	FDC735KXZE1	FDC800KXZE1	FDC850KXZE1	FDC900KXZE1	FDC950KXZE1	FDC1000KXZE1
Combination (FDC)		224KXZE1	224KXZE1	280KXZE1	280KXZE1	280KXZE1	335KXZE1
		224KXZE1	280KXZE1	280KXZE1	280KXZE1	335KXZE1	335KXZE1
		280KXZE1	280KXZE1	280KXZE1	335KXZE1	335KXZE1	335KXZE1
Nominal horse power		26HP	28HP	30HP	32HP	34HP	36HP
Power source		3Phase 380-415V, 50Hz					
Starting current	A	15					
Max current	A	74.4	85.2	96			
Nominal capacity	Cooling	73.5	80.0	85.0	90.0	95.0	100.0
	Heating	82.5	90.0	95.0	100.0	106.0	112.0
Electrical characteristics	Power consumption	17.1	19.3	21.1	22.7	24.3	25.9
	Cooling Heating	18.2	19.7	20.6	21.9	23.5	25.1
Exterior dimensions	H x W x D	2048x4050x720					
Net weight	kg	885	930	975	975		
Refrigerant charge	R410A	11.0x2+11.5	11.0+11.5x2	11.5x3			
Refrigerant piping size	Liquid line	ø15.88(5/8")					
	Gas line	ø31.75(1 1/4") [ø34.92(1 3/8")]					
	Oil equalization	ø9.52(3/8")					
Capacity connection	%	160					
Number of connectable indoor units		78	80	80	80	80	80

1. The data are measured under the following conditions (ISO-T1). Cooling: Indoor temp. of 27°CDB, 19°CWB, and outdoor temp. of 35°CDB. Heating: Indoor temp. of 20°CDB, and outdoor temp. of 7°CDB, 6°CWB. Piping length is 7.5m.
2. Sound pressure level indicates the value in an anechoic chamber. During operation these values are somewhat higher due to ambient conditions.
3. 'tonne(s) of CO₂ equivalent' means a quantity of greenhouse gases, expressed as the product of the weight of the greenhouse gases in metric tonnes and of their global warming potential.
4. [] : Pipe sizes applicable to European installations are shown in parentheses.



Dimensions

All measurements in mm.

FDC224KXZE1

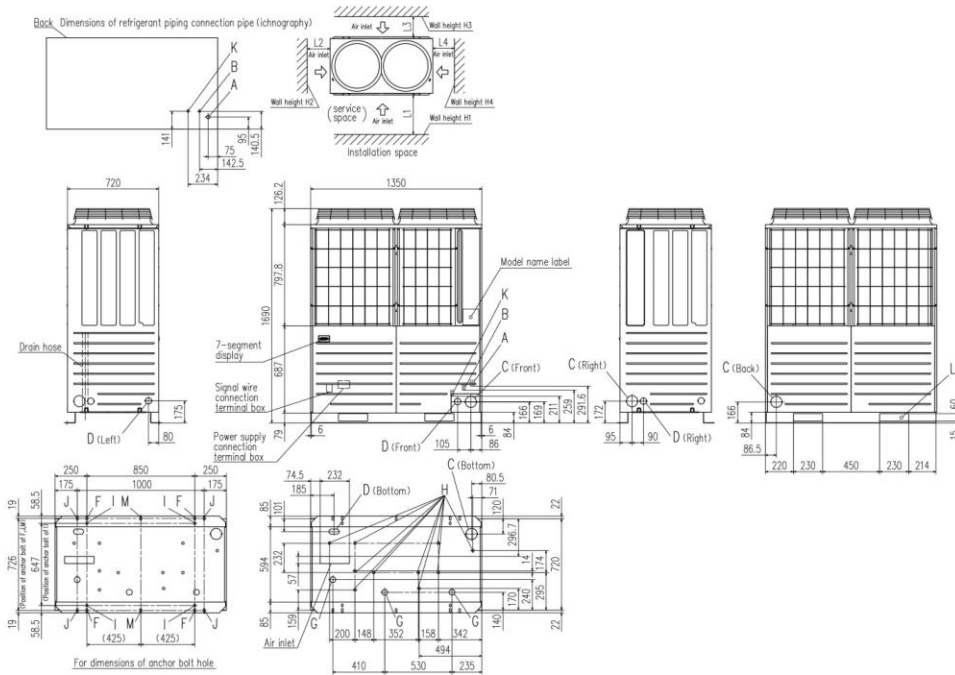

Mark	Content	224
A	Refrigerant gas piping connection pipe	ø19.05 (Brazing)
B	Refrigerant liquid piping connection pipe	ø9.52 (Flare)
C	Refrigerant piping exit hole	ø88 (or ø100)
D	Power supply entry hole	ø50 (Right · Left · Front), Long hole 40 x 80 (Bottom)
F	Anchor bolt hole	M10 x 4 places
G	Drain waste water hose hole	ø45 x 3 places
H	Drain hole	ø20 x 10 places
K	Refrigerant oil equalization piping connection pipe	ø9.52 (Flare)
L	Carrying in or hole for hanging	230 x 60

Installation example		
Dimensions	1	2
L1	500	Open
L2	10(30)	10(30)
L3	100	100
L4	10(30)	Open
H1	1500	Open
H2	No limit	No limit
H3	1000	No limit
H4	No limit	Open

() : In case it is the promised installation location that the outdoor unit is used on conditions with the ambient temperature of 43°C or more.

