



Mar. 12, 2012
T-S-006 / 766-90174

Addition of partial stroke test device for Mechanical Trip Throttle Valve during operation

REASON FOR SUGGESTION:

In case of long-term continuous operation, the trip throttle valve is kept fully open until the next periodical overhaul.

During the operation, scale sticking between the valve spindle and the bushing may prevent the valve from being fully closed even if the trip signal is given.

DETAILS OF SUGGESTION:

Partially modify the mechanical trip throttle valve, as shown in the attached drawing. During the operation, periodically check the valve spindle independently for tripping so that it can be confirmed beforehand that there would be no problem to occur even in case of emergency shutdown.

Partial Stroke Test Device for Mechanical Trip Throttle Valve during Operation

In long-term continuous operation, the scale may stick to the valve spindle and prevent it from tripping. Measures can be taken against this by adding a partial stroke test device to the valve which will not only ensure the normal tripping but also remove scale, if any sticking, without need of stopping the operation. (The recent turbines have been equipped with this device according to API612.)

[Example showing the mechanical vertical type trip throttle valve]

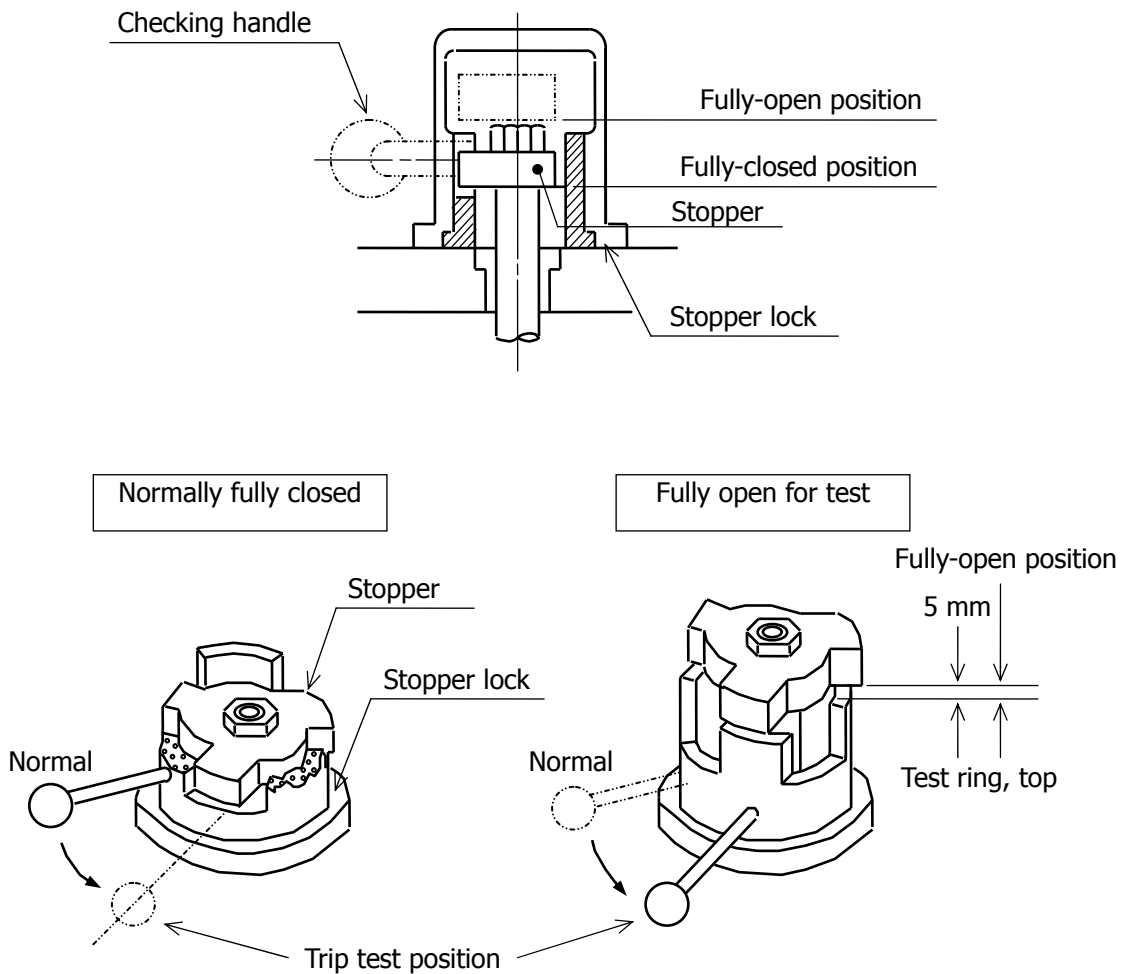

Install the testing device for the mechanical horizontal type trip throttle valve beneath the spring retainer. Other functions are the same as above.

Partial Stroke Test Device 3D image after modification

[Mechanical Vertical type TTV]

Normal operation (full open)

Partial stroke test

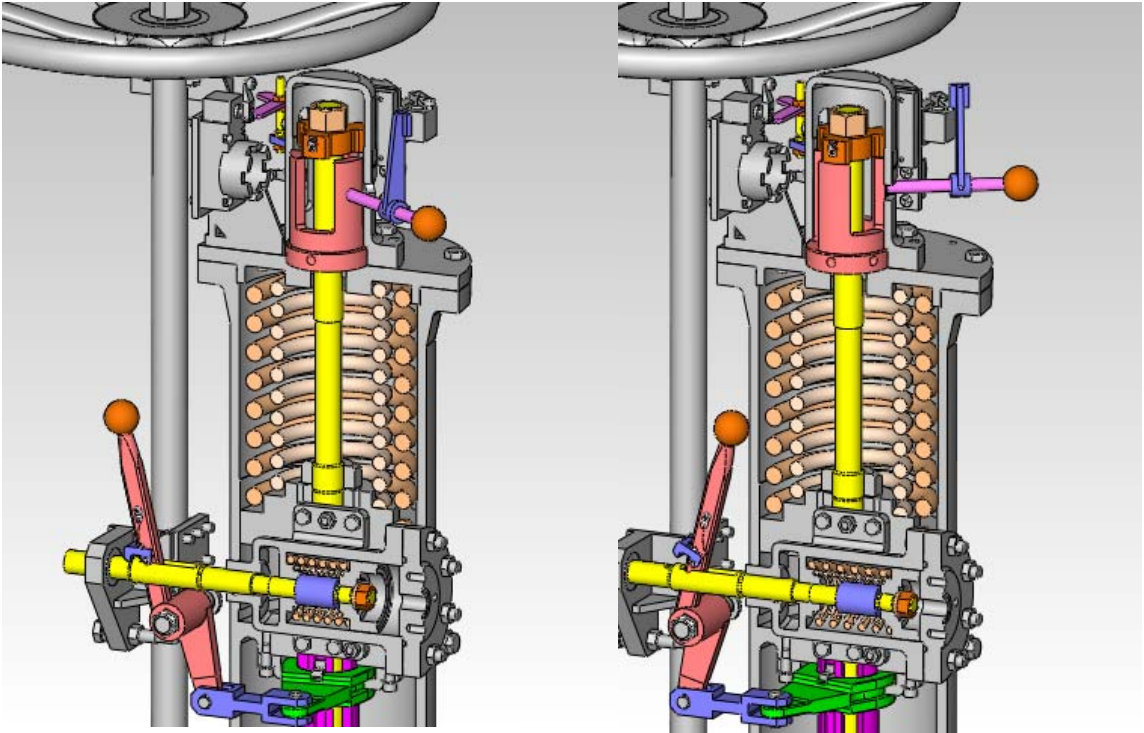

[Mechanical Horizontal type TTV]

Normal operation (full open)

Partial stroke test

