

# STATUS OF THE SUPERCONDUCTING CAVITY DEVELOPMENT FOR ILC AT MHI

K. Sennyu<sup>#</sup>, H. Hara, M. Matsuoka, T. Yanagisawa  
 Mitsubishi Heavy Industries, Ltd, Kobe, Hyogo, 652-8585, Japan

## Abstract

MHI has supplied superconducting cavities for the KEKB Crab project, ERL (Energy Recovery Linac) project and the ILC R&D (STF: Superconducting RF Test Facility in KEK) project to KEK in Japan for the last few years. We are improving the technology to design and fabricate the superconducting cavities for ILC R&D. We can present some examples of our work that have improved the quality and productivity of the superconducting cavities. We designed and fabricated four STF 1.0-type cavities and two STF 1.5-type cavities. The status of superconducting cavity development for ILC at MHI is described in this paper.

## INTRODUCTION

STF (Superconducting RF Test Facility) is under construction at KEK. MHI designed and fabricated six superconducting RF cavities for STF. Four of these cavities have undergone vertical testing at KEK and are under horizontal testing. [1] The two other cavities will be tested this autumn by KEK. [2]

## RECENT ACTIVITY CONCERNING SUPERCONDUCTING CAVITY

We have fabricated various types of superconducting cavities for the last few years as shown in table 1.

Table 1: Recent activity concerning the superconducting cavity

Project	2005	2006	2007	2008
KEK Crab cavity (608 MHz)	Cavity and Cryostat fabrication 1cell 2sets	install to KEKB	Operation	
KEK ERL R&D (300MHz)		Fabrication 1cell 2sets	Vertical test 9cell 3shots RF test	Fabrication 2cell 1shot RF test
KEK ILC R&D (300MHz)	STF1.0 Cavity fabrication 9cell 4sets	Vertical test 4sets	Jacket dressing Horizontal test STF1.5 Cavity fabrication 9cell 2sets RF test	

<sup>#</sup>katsuya\_sennyu@mhi.co.jp

## FEATURE OF STF 1.0-TYPE CAVITY

### Main Goal of STF1.0-Type Cavity

The main goal of STF 1.0-type cavity is to design and fabricate a rigid jacket system with frequency tuner in order to decrease Lorentz detuning. [3]

To make a jacket system rigid, some modifications of TESLA cavity are summarised as follows:

- Thick titanium baseplate.
- Thick beam tube by machining from the ingot.
- Thick bellows flange.
- Thick jacket body.
- Rigid frequency tuner system.[4]

### Main Problem of STF1.0-Type Cavity

We could not achieve a good cavity performance as shown by the KEK vertical test in fig.2. [5] The limitation of the performance might be the result of the quality of the welding bead at the equator of cells.

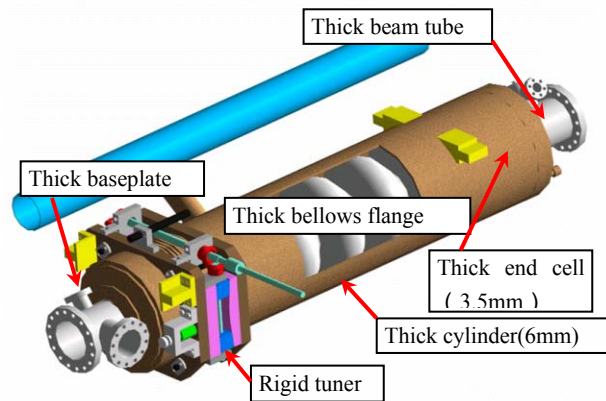

Figure 1: The STF1.0 cavity with a rigid jacket system.

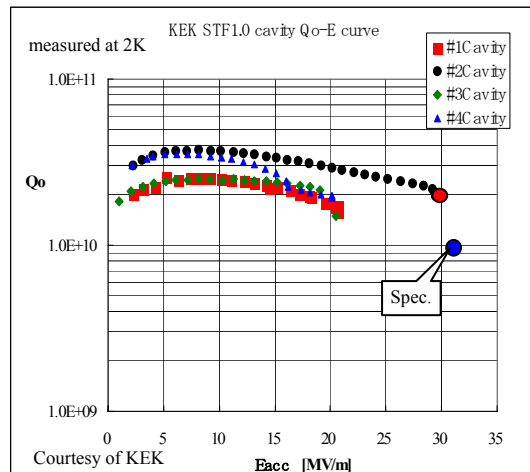

Figure 2: The frequency tuner with test stand

## FEATURE OF STF 1.5-TYPE CAVITY

### Main Goal of the STF 1.5-Type Cavity

Main goal of the STF 1.5-Type cavity is to improve the cavity performance. (see Fig.3)

To improve cavity performance some modifications from STF 1.0-type cavity were made as follows:

- Improving the welding condition of the equator. (The beads inside of the cavity are made smoother than the STF 1.0-type cavity.)
- Assembling parts before EBW in a cleaner divided circumstance.
- Cleaning the edge with Chemical Polish before every EBW except of stiffener.



Figure 3: The STF 1.5-type cavities with transport jig

New cavities are prepared for the KEK vertical test.

## IMPROVEMENT FROM STF 1.5 TO S1 PROGRAM

Next goal after getting a stable cavity performance is to improve the productivity of the STF 1.5-type cavity. Now we are designing details based on our proposal to KEK. The main improvements under consideration for the next step from STF1.5 are described below.

### Machining to Forming

We should reduce parts machining and use the forming as described below for example:

- **HOM coupler:** We need to study simplifying HOM coupler design especially inner conductor as shown in Fig. 4. We propose to fabricate the stub the same thickness as antenna. We should to fabricate the outer conductor by deep drawing and bulge forming in place of machining.
- **Beam tube:** We should fabricate the beam tube to more than 4mm thickness by deep drawing and bulge forming in place of machining.
- **Baseplate:** We should fabricate the baseplate to more than 20mm thickness by pressing in place of machining.

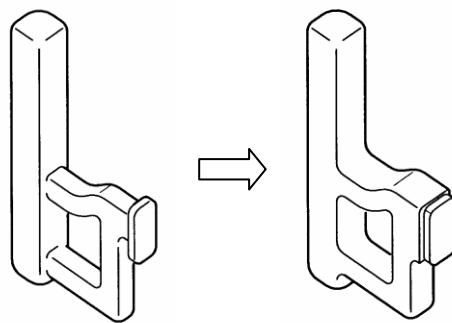

Figure 4: The inner conductor of the HOM coupler for STF1.5 (left) and next step (right).

## SOME R&D FOR ILC

A lot of research and development is needed to realize ILC project from the viewpoint of cavity productivity.

### Welding productivity

We should try to reduce the welding line described below for example:

- **Flange joints and stiffener joints:** We should develop the joining flanges and beam tubes and the joining stiffeners and half-cells by brazing not welding. (see fig.5) We did the basic mechanical test at R.T. concerning the niobium and titanium joints and the niobium and niobium joints by brazing as shown table 2. (Titanium might take the place of niobium-titanium because of the temperature at the cavity heat treatment.) Three brazing material were chosen from the viewpoint of the brazing temperature and matching with two materials. This result is summarized as follows.
  - There are some conditions enough shearing strength for Nb/Ti joints and Nb/Nb joints.
  - The absorbing energy of Nb/Ti joints by charpy impact test is very small. Some changes of brazing condition are needed to use these joints.
  - Only a slight change of brazing condition is needed to use Nb/Nb joints at R.T. After improving the brazing condition, we need a mechanical test at R.T. and at low temperature.

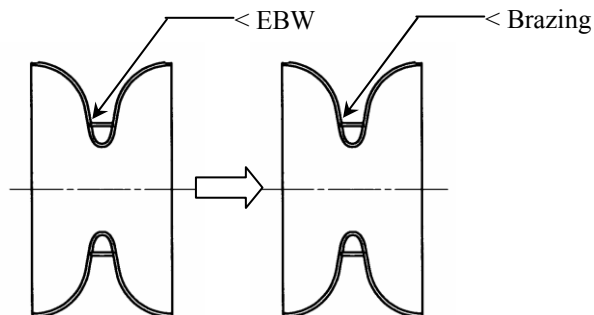

Figure 5: The procedure for joining the stiffener and half-cell for STF1.5 (left) and ILC proposal (right).

Table 2: Basic mechanical test about brazing joints

material	Brazing material	Surface treatment	Ave. Shearing strength (N/mm <sup>2</sup> )	Break point	Ave. Absorbing Energy K <sub>v2</sub> (J)	Leak test	Remarks
Nb/Ti	A	-	124	Nb	0.58	○	
		○	122	Nb	-	○	
	B	-	45	joint	0.55	○	
		○	40.7	joint	-	-	
	C	-	42.7	joint	0.6	○	
		○	39.2	joint	-	-	
Nb/Nb	A	-	54.6	joint	-	-	
	B	-	120.6	Nb/joint	9.78	-	1 sample 22J
	C	-	121.6	Nb/joint	4.05	-	
		○	106.6	joint	-	-	

Heat treatment: 923K x 3H, 77K x 5 min.

Test temperature: room temperature

- **Iris:** We should decrease the iris welding by using a new forming method as shown in fig.6. This procedure can also decrease the cavity deformation without iris welding. The features of this procedure are summarized as follows:
  - This procedure needs only one machine from forming to machining the edge of the joints.
  - It will take less than thirty minutes per dumbbell cell for forming to machining.
  - The quality of the inner surface of cell depends on the quality of the tube. We have to develop a higher quality tube.
  - The shape of the cavity is very good compared to the design.
  - We need to fabricate a test cavity and test the cavity performance after some improvements.

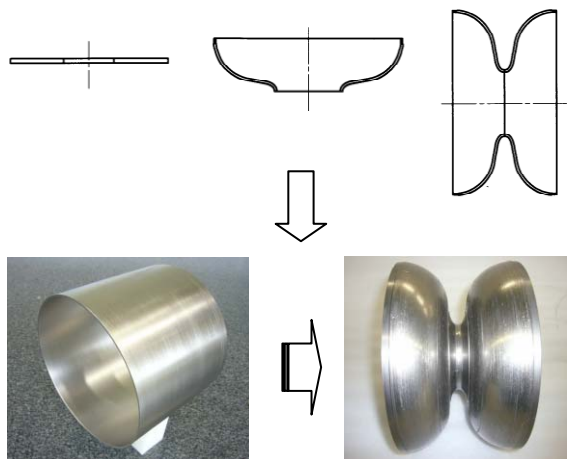

Figure 6: The new forming method (bottom) to decrease the iris welding compared to the traditional method (top)

## CONCLUSION

- We have supplied some superconducting cavities for some Japanese projects at KEK for the last few years. We are improving the technology to design and fabricate the superconducting cavities for ILC R&D.
- We designed and fabricated four STF 1.0-type cavities and recognized some problems and some improvements that needed to be made.
- We fabricated two STF 1.5-type cavities superior in performance to the STF 1.0-type cavities. The cavity performance will be tested this autumn by KEK.
- Some ideas to improve productivity for ILC R&D (S1 program) were proposed. Some R&D is planned by KEK.
- We have more ideas to improve productivity for ILC. We propose using brazing joints instead of welding joints and using new forming procedure.

## ACKNOWLEDGEMENT

Special thanks to S. Noguchi, N. Toge, E. Kako, Y. Yamamoto, T. Shishido, K. Watanabe at KEK for this paper.

## REFERENCES

- [1] E. Kako, et al., "Cryomodule Tests of the STF Baseline 9-cell Cavities at KEK", 11<sup>th</sup> EPAC'08, Genoa, Italy, (2008) MOPP131
- [2] Y. Yamamoto, et al., "Cavity Diagnostic System for the Vertical Test of the STF Baseline 9-cell Cavities at KEK", 11<sup>th</sup> EPAC'08, Genoa, Italy, (2008) MOPP044
- [3] K. Sennyu, et al., "Design and Fabrication of Superconducting Cavities for Industrialization", 13<sup>th</sup> SRF2007, Beijing, China, (2007)WEP48
- [4] S. Noguchi, et al., "Review of New Tuner Design", 13<sup>th</sup> SRF2007, Beijing, China, (2007) WE303
- [5] E. Kako, et al., "Vertical Test Results STF Baseline 9-cell Cavities at KEK", 13<sup>th</sup> SRF2007, Beijing, China, (2007) WEP10